

User Manual

Tektronix

**Phaser™ 240
Color Printer**

Copyright © 1995 by Tektronix, Inc., Wilsonville, Oregon. Printed in the United States of America. All rights reserved. Contents of this publication may not be reproduced in any form without permission of Tektronix, Inc.

This instrument, in whole or in part, may be protected by one or more U.S. or foreign patents or patent applications. Information provided upon request from Tektronix, Inc., P.O. Box 1000, Wilsonville, Oregon 97070-1000.

If acquired subject to FAR or DFARS, the following shall apply:

- Unpublished — rights reserved under the copyright laws of the United States.
- Restricted Rights Legend — Use, duplication, or disclosures by the U.S. government is subject to restrictions as set forth in subparagraph (c)(1)(ii) of the Rights in Technical Data and Computer Software clause at DFARS 252.227-7013, or in subparagraph (c) (2) of the Commercial Computer Software – Restricted Rights clause at FAR 52.227-19, as applicable. Tektronix, Inc., P.O. Box 1000, Wilsonville, Oregon 97070-1000.

Tektronix[®] is a registered trademark of Tektronix, Inc. TekColor[™] and ColorCoat[™] are trademarks of Tektronix, Inc. Phaser[™] is a trademark of Tektronix, Inc. for color printers and related products.

Adobe[™] and PostScript[™], and IntelliSelect[™] are trademarks of Adobe Systems, Incorporated which may be registered in certain jurisdictions.

Times[™], Helvetica[™] and Palatino[™] are trademarks of Linotype-Hell AG and/or its subsidiaries.

UNIX is a trademark of AT&T Bell Laboratories.

Windows is a trademark of Microsoft Corporation.

Novell[®]NetWare[®] is a registered trademark of Novell, Inc.

PCL[®] is a registered trademark of Hewlett-Packard Corporation.

PANTONE[®]* Colors generated by the Phaser 240 Color Printer are four-color process simulations and may not match PANTONE-identified solid color standards. Use current PANTONE Color Reference Manuals for accurate colors.

PANTONE Color simulations are only obtainable on these products when driven by qualified Pantone-licensed software packages. Contact Pantone, Inc. for a current list of qualified licensees.

* Pantone, Inc.'s check-standard trademark for color reproduction and color reproduction materials.

© Pantone, Inc., 1988.

Other marks are trademarks or registered trademarks of the companies with which they are associated.

Phaser™ 240 Warranty

Tektronix warrants that the Phaser 240 will be free from defects in materials and workmanship for a period of one (1) year from the date of shipment. If the Phaser 240 proves defective during the respective warranty period, Tektronix, at its option, will either repair the defective product without charge for parts and labor, or provide a replacement in exchange for the defective product.

This warranty applies only to products returned to the designated Tektronix depot or the Tektronix authorized representative from which the product was originally purchased. For products returned to other locations, Customer will be assessed the applicable service charge. The above limitation shall not apply within the European Economic Area, where products may be returned for warranty service to the nearest designated service depot regardless of the place of purchase.

In order to obtain service under this warranty, Customer must provide the applicable office of Tektronix or its authorized representative with notice of the defect before the expiration of the warranty period and make suitable arrangements for the performance of service. Customer shall be responsible for packaging and shipping the defective product to the service center designated by Tektronix or its representative, with shipping charges prepaid. Tektronix or its representative shall pay for the return of the product to Customer. Customer shall be responsible for paying any associated taxes or duties.

This warranty shall not apply to any defect, failure or damage caused by improper use or improper or inadequate maintenance and care. Tektronix shall not be obligated to furnish service under this warranty:

- a. to repair damage resulting from attempts by personnel other than Tektronix representatives to install, repair or service the product;
- b. to repair damage resulting from improper use or connection to incompatible equipment;
- c. to repair any damage or malfunction caused by the use of non-Tektronix supplies or consumables;
- d. to repair a product that has been modified or integrated with other products when the effect of such modification or integration increases the time or difficulty of servicing the product; or
- e. to repair damage or malfunction resulting from failure to perform user maintenance and cleaning at the frequency and as prescribed in the user manual;

THE ABOVE WARRANTIES ARE GIVEN BY TEKTRONIX WITH RESPECT TO THIS PRODUCT IN LIEU OF ANY OTHER WARRANTIES, EXPRESS OR IMPLIED. TEKTRONIX AND ITS VENDORS DISCLAIM ANY IMPLIED WARRANTIES OF MERCHANTABILITY OR FITNESS FOR A PARTICULAR PURPOSE. TEKTRONIX' RESPONSIBILITY TO REPAIR OR REPLACE DEFECTIVE PRODUCTS IS THE SOLE AND EXCLUSIVE REMEDY PROVIDED TO THE CUSTOMER FOR BREACH OF THIS WARRANTY. TEKTRONIX AND ITS VENDORS WILL NOT BE LIABLE FOR ANY INDIRECT, SPECIAL, INCIDENTAL, OR CONSEQUENTIAL DAMAGES IRRESPECTIVE OF WHETHER TEKTRONIX OR THE VENDOR HAS ADVANCE NOTICE OF THE POSSIBILITY OF SUCH DAMAGES.

Users safety summary

Terms in manual: CAUTION Conditions that can result in damage to the product.
WARNING Conditions that can result in personal injury or loss of life.

Power source: Do not apply more than 250 volts RMS between the supply conductors or between either supply conductor and ground. Use only the specified power cord and connector. Refer to a qualified service technician for changes to the cord or connector.

Operation of product: Avoid electric shock by contacting a qualified service technician to replace fuses inside the product. Do not operate without the covers and panels properly installed. Do not operate in an atmosphere of explosive gases.

Safety instructions: Read all installation instructions carefully before you plug the product into a power source.

Terms on product: CAUTION A personal injury hazard exists that may not be apparent. For example, a panel may cover the hazardous area. Also applies to a hazard to property including the product itself.
DANGER A personal injury hazard exists in the area where you see the sign.

Care of product: Disconnect the power plug by pulling the plug, not the cord. Disconnect the power plug if the power cord or plug is frayed or otherwise damaged, if you spill anything into the case, if product is exposed to any excess moisture, if product is dropped or damaged, if you suspect that the product needs servicing or repair, and whenever you clean the product.

Ground the product: Plug the three-wire power cord (with grounding prong) into grounded AC outlets only. If necessary, contact a licensed electrician to install a properly grounded outlet.

Symbols as marked on product:

DANGER high voltage:



Protective ground (earth) terminal:



Use caution. Refer to the manual(s) for information:



WARNING: If the product loses the ground connection, usage of knobs and controls (and other conductive parts) can cause an electrical shock. Electrical product may be hazardous if misused.

Contents

1 Introduction

2 Getting Set Up

At a glance 2-1

Setting up the printer 2-2

 What you get with your printer 2-2

 Printer options 2-4

 Installing the optional Lower Tray Assembly 2-5

 Removing the packing material from inside the printer 2-7

 Install the transfer roll 2-8

 Adding paper or transparencies 2-9

Installing options 2-13

Connecting the printer 2-14

 Printer ports 2-14

 LocalTalk connection 2-15

 Parallel connection 2-17

 Ethernet connection 2-18

 Connecting the power and turning on the printer 2-19

Installing a driver on your computer 2-23

 Phaser 240 drivers and utilities diskettes 2-23

 PC users 2-24

 Macintosh users 2-28

 Workstation users 2-33

Setting up PC ports (DOS) 2-34

Turning on and off the startup page 2-35

What next? 2-35

3

Printing

- Which computer? 3-1
- Printing from a PC (Windows) 3-2
- Printing from a PC (DOS) 3-3
- Printing from a Macintosh 3-4
 - Using the Phaser 240 driver 3-4
 - Using the Phaser 240 GX driver 3-5
- Printing from a Unix or VMS workstation 3-6
 - Printing from specific applications 3-8
- Margins and print area 3-9
 - Perforated paper and transparencies 3-9
 - Non-perforated plain paper 3-10
- Using two paper trays 3-11
- Selecting driver features 3-12
- Print modes 3-12
- Color corrections 3-13
- Fonts 3-14
 - Resident typefaces (PostScript) 3-14
 - Resident typefaces (PCL5) 3-15
 - Downloading fonts 3-15
 - Installing Macintosh screen fonts 3-16
- Printer languages: PostScript, HP-GL, PCL5 3-17
 - Enabling and disabling automatic language switching 3-17
- Printing hints 3-18
 - Getting the largest printed picture 3-18
 - Why should I use perforated paper? 3-18
 - How long does it take to make a print? 3-18

4 Caring for Your Printer

Overview 4-1

Importance of cleaning 4-1

When to clean 4-2

Cleaning kit 4-3

Cleaning the printer (with every transfer roll change) 4-4

Cleaning the thermal head and transfer roll guide 4-4

Cleaning the paper-feed rollers 4-5

Cleaning the paper-pick rollers 4-6

Cleaning the printer (every 5,000 prints) 4-10

Cleaning the transfer roll sensor pad 4-10

Cleaning the drum 4-12

Cleaning the exit rollers 4-13

5 Supplies

Always use Tektronix supplies 5-1

Ordering information 5-1

Supplies kits 5-1

Using plain paper 5-2

ColorCoat™ transfer roll 5-2

Use the correct paper tray for plain-paper printing 5-3

Plain-paper startup kit 5-3

Recommended paper types 5-4

Handling supplies 5-6

Removing a used transfer roll 5-7

6 Troubleshooting

- Clearing transfer roll jams 6-1
- Clearing paper jams 6-2
- Problems and solutions 6-5
 - If you can't make a print 6-5
 - Media problems 6-8
 - Problems with image size and position 6-9
 - Print quality problems 6-10
 - Startup page prints even though it is disabled 6-12
- Printing the configuration page 6-13
- Whom to call for help 6-14

7 Front and Rear Panels

- Front panel 7-1
- Rear panel 7-3
 - Static Precautions 7-3
 - DIP switches inside rear panel door 7-4

A Technical Notes

- Printer ports A-1
 - Parallel port A-1
- Specifications A-3

B Expanding Your Printing System

- Customizing your printer B-1
- Upgrade kits B-2
- Advantages of adding memory B-3
- Phaser Print B-4
- PhaserSym B-4

C Moving Your Printer

Changing the line voltage C-1

Repacking your printer C-2

D Regulatory Information

Index

Introduction

The Tektronix Phaser 240 is a thermal-wax color printer that provides superior quality A/Letter-size and A4-size color prints. The printer provides color printing at speeds up to two pages per minute with PANTONE Color-approved and TekColor imaging enhancements.

The Phaser 240 delivers 300 x 300 dots-per-inch (dpi) color resolution in its default configuration. With a minimum of 8 Mbytes of additional memory installed, a 600 x 300 dpi resolution printing mode gives you sharper, clearer thermal-wax prints.

An optional Lower Tray Assembly is available for the printer; the optional Lower Tray Assembly provides dual-tray printing capability. Printing from two trays allows you to have paper and transparencies ready for printing at all times without switching trays. You can also load the same media in both trays.

The Phaser 240 printer provides vivid color on common laser paper, coated thermal-transfer paper, and transparencies. A specially formulated transfer roll gives prints on standard laser paper the brilliant color quality previously available only with coated thermal-transfer papers.

By using Tektronix *perforated* paper and transparencies, you can print full A/Letter-size or A4-size images with ISO (International Standards Organization) margins (5 mm; 0.2 in.).

The Phaser 240 printer works with Macintosh computers, IBM Personal Computers and compatibles, and various workstations. You can print from several computers at the same time because the printer supports simultaneous input through parallel and LocalTalk ports. An optional Ethernet interface provides Ethernet connectivity with EtherTalk and Novell NetWare protocols. The TCP/IP protocol is also available by purchasing an additional option.

The printer lets you make color prints from a variety of software applications since it incorporates Adobe's PostScript Level 2 software. The printer also accepts HP-GL (Hewlett-Packard Graphics Language) files and monochrome PCL5 (Printer Command Language) files. The Phaser 240 printer interfaces automatically switch between all of the three supported languages: PostScript, HP-GL, and PCL5.

The Phaser 240 has 17 resident PostScript fonts, upgradable to 39 fonts. The printer accepts the following types of fonts:

- Adobe Type 1
- Adobe Type 3
- TrueType
- A variety of user-defined fonts

To order supplies such as paper, transparencies, or transfer rolls, refer to the supplies information sheet that is shipped with the printer and contact your local dealer or, in the U.S.A., call Tektronix at **1-800-835-6100**.

Getting Set Up

At a glance

To install your printer, perform the steps listed here. The following pages provide detailed installation instructions. If you used the pictorial installation instructions, you have already performed Steps 1 and 2. Begin with Step 3; turn to “Installing a driver on your computer” on page 2-23.

- 1. Setting up the printer**
Putting all the pieces together: unpacking the printer and accessories, checking the inventory, removing the packing material, installing the optional Lower Tray Assembly, loading the transfer roll, loading the paper tray(s), setting the media switch for paper or transparencies, and installing memory, font or Ethernet options.
- 2. Connecting the printer**
Connecting all necessary cables and turning on the printer.
- 3. Installing a driver on your computer**
Using the Phaser 240 diskettes to install a driver on your computer (Macintosh or Windows).
- 4. Setting up computer ports**

Setting up the printer

What you get with your printer

1. Paper tray(s)
2. Sample transfer roll
3. Power cord
4. TekColor Care envelope (includes the registration card)
5. Cleaning kit
6. *Phaser 240 Color Printer User Manual*
7. Supplies information sheet
8. Transparencies
9. Thermal-transfer paper
10. *Phaser 240 Drivers and Utilities Printing Reference*
11. Tektronix Phaser 240 drivers and utilities diskettes

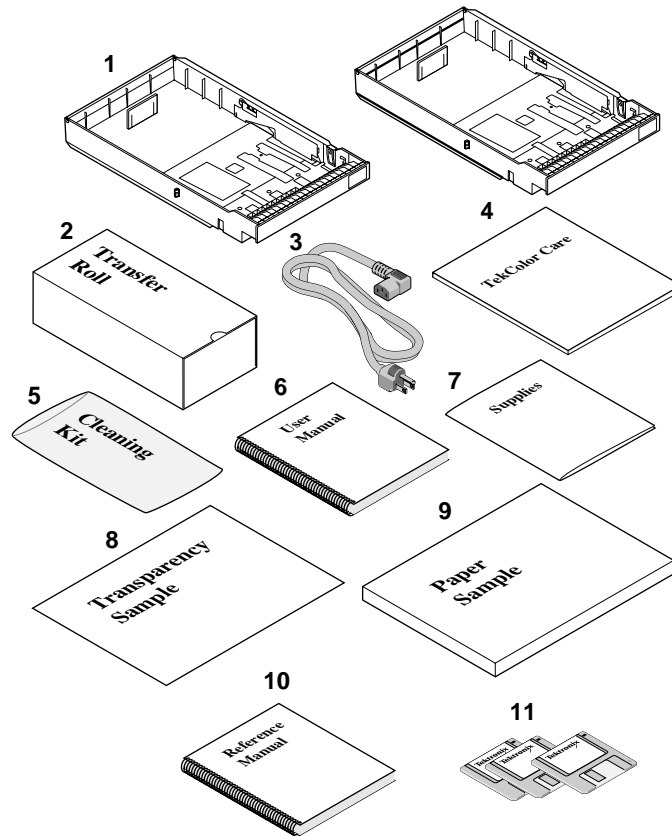

9238-01

Printer options

1. Lower Tray Assembly
2. Ethernet SIMM
3. Font SIMM (adds 22 fonts for a total of 39 fonts)
4. Memory (add a single 4-, 8-, or 16-Mbyte SIMM)
5. *Network Utilities for Phaser Color Printers* manual and diskettes

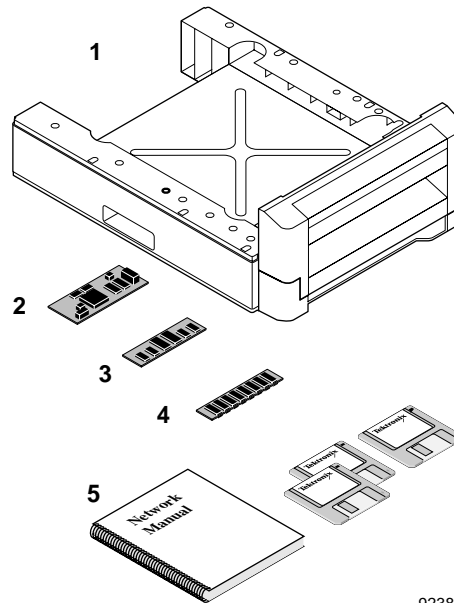

9238-02

Installing the optional Lower Tray Assembly

An optional Lower Tray Assembly is available for the Phaser 240 printer (Tektronix order number 4681FTA). With the optional Lower Tray Assembly installed, you can configure the printer to be dual-media capable. For example, you might want to load paper in one tray and transparency in the other.

Note *The printer weighs about 18 kg (40 lbs.). Observe standard precautions for lifting heavy objects.*

Warning *The printer is not permanently attached to the Lower Tray Assembly. Take care to move the printer and Lower Tray Assembly together by using the slots on the sides of the Lower Tray Assembly. Moving the printer incorrectly may damage it and may cause personal injury.*

If you have a Lower Tray Assembly, install it by performing these steps:

1. Place the printer on top of the Lower Tray Assembly.
2. Make sure that the left and right alignment pins fit in the holes in the base of the printer.
3. Plug the Lower Tray Assembly cable into the printer.
4. To move the printer, use the slots on either side of the Lower Tray Assembly. Observe standard precautions for lifting heavy objects. To move the printer more than a few feet, it is easier to disconnect the Lower Tray Assembly and move it separately from the printer.

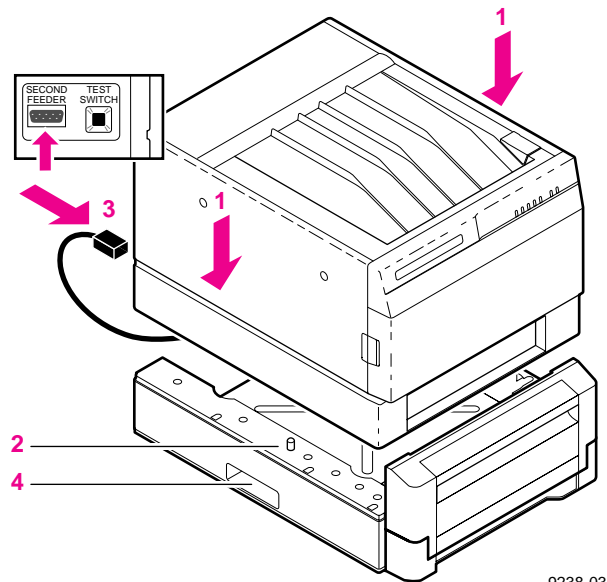

9238-03

Note When using the printer with the optional Lower Tray Assembly installed, make sure that the door covering the upper slot is closed. You cannot print from the lower tray with the door open.

Removing the packing material from inside the printer

1. Remove the packing tape from the top and front covers.
2. Press the button; open the top cover.
3. Remove the shipping material from the sides of the drum. (Keep all shipping material for storing or shipping the printer).

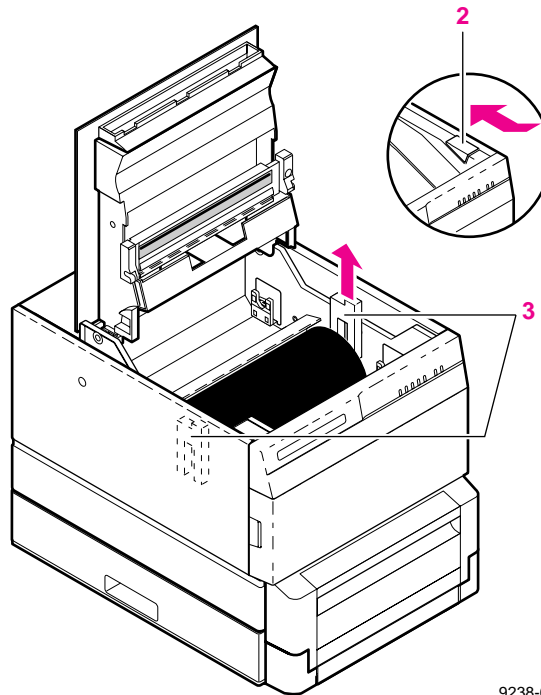

9238-04

Install the transfer roll

Note *ColorCoat™ transfer rolls are used with common laser paper and perforated premium laser paper; Black and 3-Color transfer rolls are used with Tektronix transparencies and thermal-transfer paper.*

With the top cover still open, install the transfer roll:

1. Remove the transfer roll from the box. Remove the shipping foam from the transfer roll. Remove the foam clip from the full end of the roll.
2. Hold the transfer roll so that the black band on the roll is on your left.
3. With the black band on the roll to your left, place the empty end of the roll in the slots at the front of the printer.
4. Place the full end of the roll in the slots at the back of the printer.
5. Turn the full end of the roll to remove slack.
6. Close the cover.

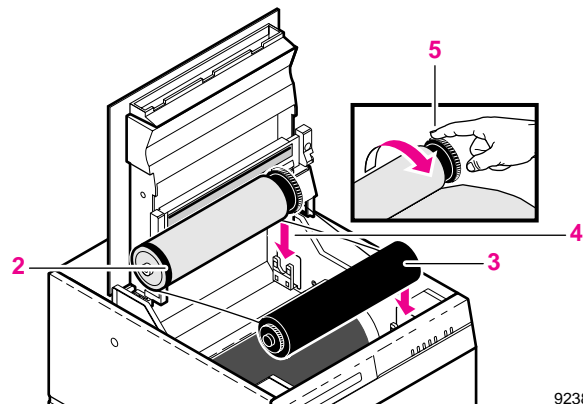

9238-05

Adding paper or transparencies

Unpack the paper tray. Be sure to remove all adhesive tape.

Note *The printer uses a different paper tray for each paper size (Letter, Letter-perforated, A4, A4-perforated). The trays are **not** adjustable.*

1. If you are using a tray for perforated paper or transparencies, set the selection switch on the tray (1) for paper or transparencies. Trays for non-perforated plain paper do not have this switch.

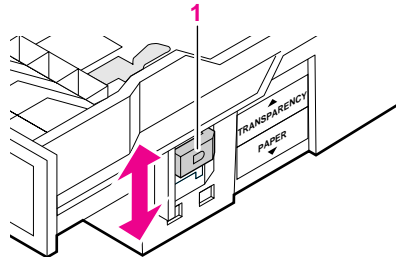

9238-06

2. Make sure that the metal plate is all the way down. If necessary, push the metal plate down until it clicks into place. Do not attempt to change the position of the vertical tab (3) at the back of the paper tray.

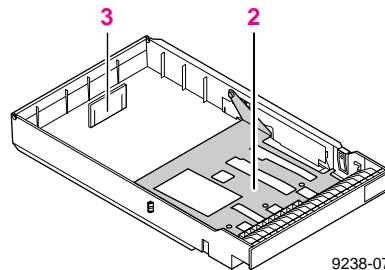

9238-07

2 Getting Set Up

3. Fan the paper or transparencies.

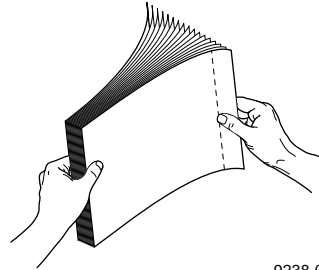

9238-08

4. Load perforated paper or transparencies with the perforations toward the front of the tray.
5. Place paper or transparencies in the tray under the hooks. Load transparencies with the film side up. Load thermal-transfer paper with the shiny side up (not applicable for laser paper).

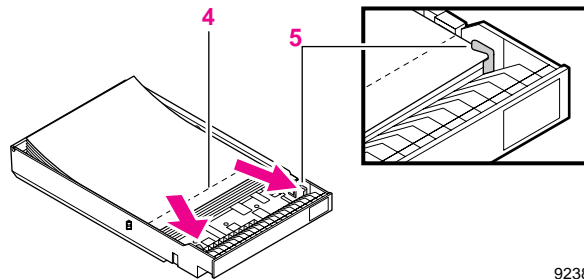

9238-09

6. If your printer has a single paper tray, push the paper tray into the slot.

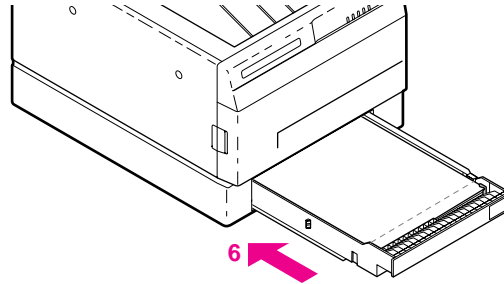

9238-10

2 Getting Set Up

7. If your printer has a Lower Tray Assembly:
 - a. Install a tray in the lower slot.
 - b. Open the door to install a tray in the upper slot.

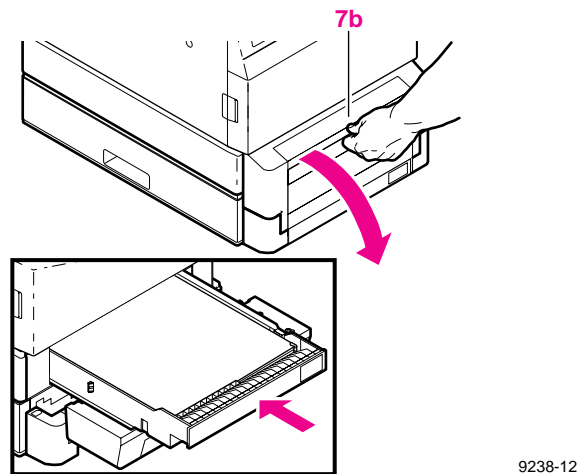
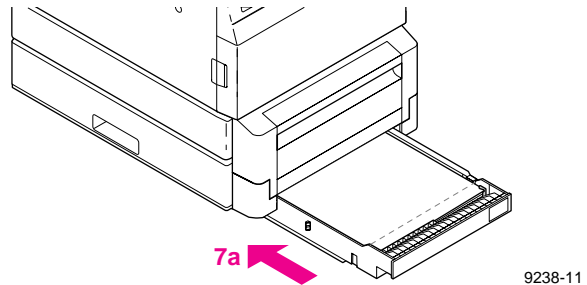

Installing options

When you order font, memory, or Ethernet options for the Phaser 240, they are shipped in separate boxes. These options must be installed in the printer before you make communication connections and power up the printer. Follow the instructions included with each option to complete the installation.

If you ordered the optional 22 fonts for your printer and you are using a Macintosh computer, you'll need to also install the screen fonts on the computer. Refer to the *Phaser 240 Drivers and Utilities Printing Reference* for more information.

Connecting the printer

Printer ports

The Phaser 240 printer is shipped standard with the following data ports:

- LocalTalk
- Parallel

The Phaser 240 also has an Ethernet connector located on the rear panel. An optional Ethernet interface SIMM must be installed to activate the connector. The optional Ethernet interface provides Ethernet connectivity with EtherTalk, Novell NetWare, and TCP/IP protocols.

All ports and network protocols are simultaneously active. The printer accepts print jobs on a first-come, first-served basis.

Note *Always make connection to the printer's interface ports **before** you turn on the printer.*

LocalTalk connection

You can make LocalTalk connections between the printer and a single computer or on a LocalTalk network using a *daisy-chain* setup. If your LocalTalk installation is complex, or if you need assistance, contact your network system administrator.

LocalTalk connectors and cables are available through your dealer. This illustration shows two commonly used types of LocalTalk connectors:

1. Self-terminating connector
2. Connector that requires an external terminator, depending on your network configuration

Note *Depending on the type of LocalTalk cables you use and your network configuration, you might need to use terminators at certain points in the installation. Refer to the documentation for your LocalTalk connectors and cables for details.*

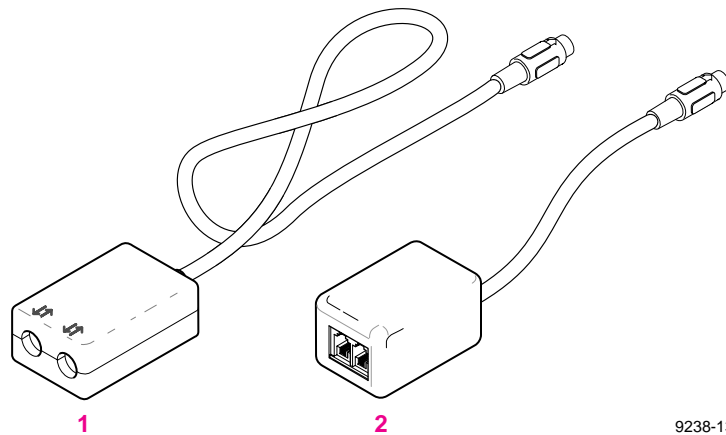

9238-13

Note *LocalTalk is sometimes referred to as AppleTalk. LocalTalk refers to the physical connection; AppleTalk is the protocol.*

Connecting the printer to a single computer using LocalTalk

You can use LocalTalk connectors and cables to connect the printer directly to your computer, without connecting it to any other network. Make sure that the printer is turned *off* before making any LocalTalk connections.

1. Connect the short cable of a LocalTalk connector to the printer's LocalTalk port.
2. Connect the short cable of another LocalTalk connector to your computer's LocalTalk port.
3. Connect a LocalTalk cable from the LocalTalk connector that you have just attached to your computer to the printer's LocalTalk connector.

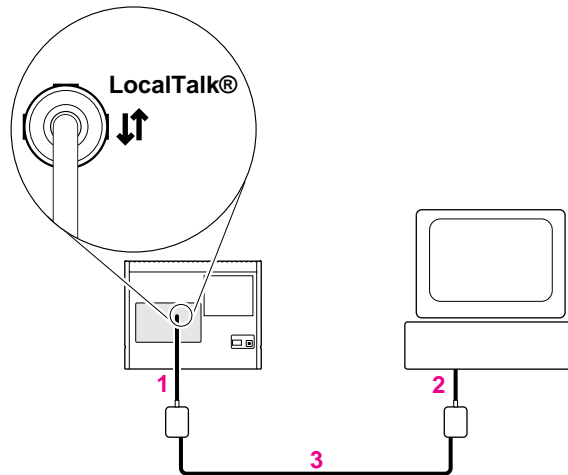

9238-14

For details on how to select the printer in the **Chooser**, change the printer's name, or set the printer's zone, refer to the manual *Phaser 240 Drivers and Utilities Printing Reference*. If you have no other connections to make, turn immediately to "Connecting the power and turning on the printer" on page 2-19.

Parallel connection

1. Connect a parallel interface cable to your computer and to the printer's parallel port.

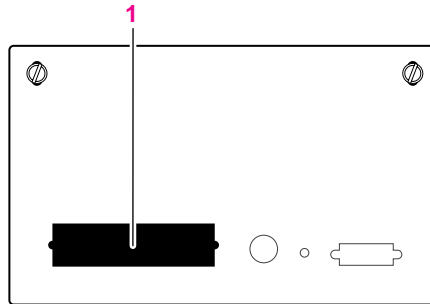

9238-15

2. If you have no other connections to make, turn immediately to “Connecting the power and turning on the printer” on page 2-19. After you turn on the printer and install a driver on your computer, you may disable timeouts on your computer's parallel port (see “Setting up PC ports (DOS)” on page 2-34).

Ethernet connection

Ethernet is a communication standard that supports very high speed data transmission. Ethernet capability is provided by an optional Ethernet SIMM that you must install before powering up the printer. For information on installing the Ethernet SIMM, refer to the documentation that accompanies the Ethernet option.

1. Connect an Ethernet interface cable to the printer's Ethernet port.

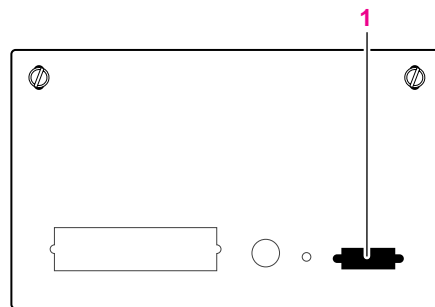

9238-16

Note For complete information on installing the Phaser 240 printer on Ethernet networks, refer to the *Network Utilities for Phaser Color Printers manual*.

Connecting the power and turning on the printer

After you have connected all the interface cables, you are ready to connect the power cord and turn on the printer.

Caution *To avoid damaging the printer, make sure that the voltage select switch is set to match the AC line voltage for your location and that the power switch is in the **off** position before connecting the power cord.*

If you move the printer to a location that uses a line voltage other than the printer's current setting, refer to "Changing the line voltage" on page C-1 for information on changing the line voltage selection switch.

1. Plug the power cord into the printer and into a grounded outlet.
2. Turn on the printer.

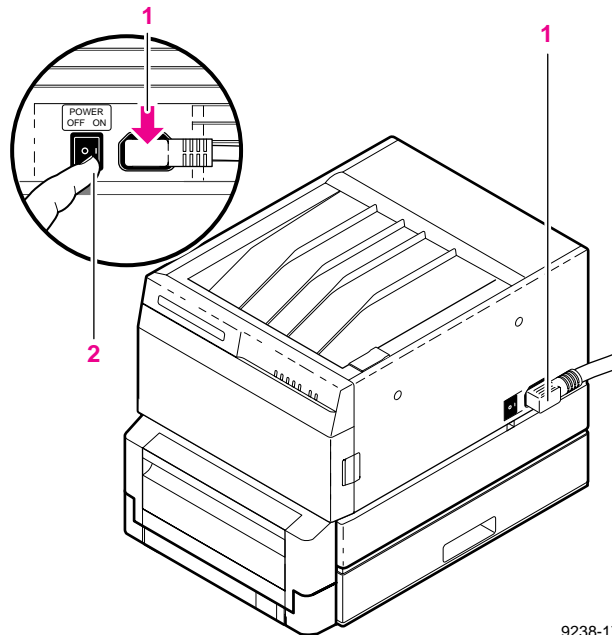

9238-17

When you turn on the printer, it executes a series of self-tests to determine if there are any problems. After running self-tests, the printer prints a startup page, if the startup page is enabled (factory default). After running self-tests and printing the startup page, the printer is ready for operation. The entire power-up sequence can last from 1 to 3 minutes, depending on the type of transfer roll installed and whether the startup page is enabled. The next few topics describe the printer's power-up sequence in detail.

Front panel at power-up

All indicators light briefly and immediately go out, except **POWER** and **READY**, which remain on for about 10 seconds. Then the **READY** indicator blinks while the **POWER** indicator remains on and the self-tests are run. When both **POWER** and **READY** are on steady (not blinking), the self-tests are complete.

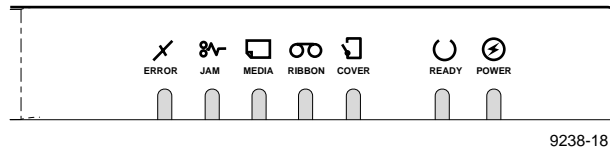

When a *standard transfer roll* is more than 75 percent used up, the front-panel **RIBBON** indicator lights, reminding you that it is time to order a new transfer roll.

When you install the *sample transfer roll* supplied with the printer, the **RIBBON** indicator may light as soon as you install it, or after you make a few prints. This is because the *sample transfer roll* contains a limited number of prints.

For complete information on the front-panel indicator lights, refer to “Front panel” on page 7-1.

Rear panel at power-up

During the first 40 - 60 seconds of the power-up sequence, the rear-panel status indicator (A) goes on and off periodically. After about 40 - 60 seconds, the status indicator blinks continuously, indicating that the printer is ready for normal operation.

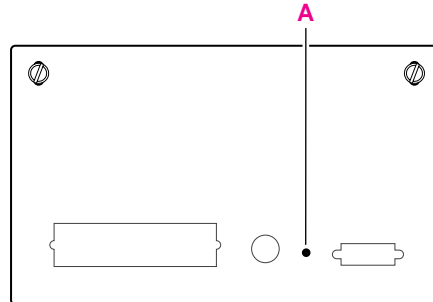

9238-19

Startup page

The startup page contains information on printer configuration and error messages. The printer produces a startup page when you turn on the printer and self-tests run successfully, if the startup page is enabled (default setting).

The printer takes from 60 to 90 seconds to print the startup page, depending on the type of transfer roll installed. The **READY** indicator blinks while the startup page is printing.

The startup page can be enabled and disabled by sending a utility file to the printer from the printer's utilities diskettes. For information, refer to the *Phaser 240 Drivers and Utilities Printing Reference*.

Note *After the startup page prints, a registration page prints if the printer has made between six and eight prints since it was built. If you have not already registered your printer, please do so by filling out this page and sending it in.*

When the printer is ready for operation

When the power-up sequence is complete, both the **POWER** and **READY** indicators remain on, indicating that the printer is ready for operation.

Installing a driver on your computer

Phaser 240 drivers and utilities diskettes

Packaged with your printer are the Phaser 240 drivers and utilities diskettes for PC and Macintosh. The drivers and utilities let you select between printer media trays, print quality modes, color correction modes and other features.

For complete details on the contents of the Phaser 240 drivers and utilities diskettes and how to use them, refer to the manual *Phaser 240 Drivers and Utilities Printing Reference*, which is shipped with the diskettes.

PC users

Microsoft Windows

The Phaser 240 diskettes include a Tektronix driver for Windows 3.1 for this printer. If you want to use Microsoft Windows applications with this printer, install the driver onto your PC.

The *Phaser 240 Drivers and Utilities Printing Reference* provides a more detailed driver installation procedure as well as complete information on using the Tektronix driver with the printer.

To install the Tektronix Windows 3.1 driver:

1. Start Windows on your PC.
2. Insert the Tektronix Windows 3.1 Driver and Printer Utilities diskette into your computer's disk drive.
3. In the main window, double-click on the **Control Panel**.
4. Double-click the **Printers** icon; the **Printers** dialog box appears.
 - a. Click the **Add** button.
 - b. In the **List of Printers**, select **Install Unlisted or Updated Printer**.
 - c. Click the **Install** button.
5. Type in the name of the disk drive that the PC diskette is in (for example, drive **B**) and click **OK**.
6. To install your printer, do the following:
 - a. Print a startup page to determine the printer's configuration. If there are 17 resident fonts, you have the standard font configuration. If you have 39 fonts, your printer has the font upgrade. Refer to "Startup page" on page 2-22 for instructions on printing a startup page.

- b. If you have the standard 17 fonts, select **Tek Phaser 240 (TekColor) 17**.

If you have the optional font upgrade (Tektronix order number 4681F1F) with 22 additional fonts (a total of 39 fonts), select **Tek Phaser 240 (TekColor) 39**.

Note *If the printer has the font upgrade, you must install the **Tek Phaser 240 (TekColor) 39** driver for Windows to recognize and use all of the printer's fonts.*

*If you select **Tek Phaser 240 (TekColor) 39** and you only have the standard 17 printer fonts, any of the additional fonts selected within an application are printed in the Courier font.*

- c. Click **OK**. The driver software you need is automatically installed.

Note *The printer's configuration page contains the information you need to set up the printer port. For information on printing a configuration page, see "Printing the configuration page" on page 6-13.*

- 7. Assign the printer to a port:
 - a. Select the printer from the list of **Installed Printers**.
 - b. Click **Set As Default Printer** if you want this printer to be the default.
 - c. Click **Connect** to display the **Connect** dialog box.
 - d. In the **Connect** dialog box, set the **Transmission Retry** value to **850**. Refer to your Windows documentation for details.

- e. In the **Connect** dialog box, select a port:

<u>Interface</u>	<u>Select</u>
Parallel	LPT1 or LPT2
Network	Network button

If you selected a parallel port, go on to Step **f**.

If you clicked on the **Network** button, the **Printers – Network Connections** dialog box appears. Fill in each item according to the printer's configuration page. Refer to your Windows documentation for details or ask your network administrator for help.

- f. Click **OK** in the **Connect** dialog box and close the **Printers** dialog box.

DOS

Check the list of supported printers in your DOS application for support of the Phaser 240 printer. If the list does not include this printer, check to see if other Tektronix Phaser series printers are listed and choose one of those. Otherwise, use a generic color PostScript driver. Refer to the *Phaser 240 Drivers and Utilities Printing Reference* for more information.

Note *Generic PostScript printer drivers do not have information about this particular printer, for example, its page sizes or its image area size. Using a standard Letter- or A4-size media selection should produce acceptable results.*

Macintosh users

Install the Phaser 240 driver onto your Macintosh to make the best use of the printer. Phaser 240 driver allows you to select Tektronix Phaser page sizes, upper and lower paper trays, and TekColor color corrections for a Phaser 240 printer.

- Use the **Phaser 240** driver if you are using System Software 6.0.7, or 7.0 and later. The Phaser 240 driver is a Tektronix-modified version of Apple's LaserWriter 7.1.2 printer driver. If you are using System Software 7.5 with QuickDraw GX, you must disable QuickDraw GX before using this driver; the Phaser 240 driver does not work with QuickDraw GX.
- Use the **Phaser 240 GX** driver if you are using QuickDraw GX and System Software 7.5. The Phaser 240 GX driver works with QuickDraw GX applications and with non-QuickDraw GX applications.

The *Phaser 240 Drivers and Utilities Printing Reference* provides detailed driver installation procedures and complete information on using the Tektronix drivers with your printer.

In addition to installing a driver, you may also need to install PPDs (PostScript printer description files) for applications such as Aldus PageMaker and QuarkXPress. For details on printing from an application, refer to the *Phaser 240 Drivers and Utilities Printing Reference*.

Installing the Phaser 240 driver

1. Make sure that your Macintosh is turned on with System Software version 6.0.7, 7.0 or later installed.
2. Insert the Macintosh Driver and Printer Utilities diskette into the disk drive. When the diskette appears on the desktop, it should be open, showing the icons inside.
3. Drag the **Phaser 240** driver icon from the diskette to the **closed System Folder** icon on your Macintosh hard disk.
 - **System 7.0 and later users:** at the alert message, click **OK** to automatically install the driver in the *Extensions* folder.
 - **System 6.0.7 users:** the driver is installed in the *System Folder*.
4. **System 6.0.7 users:** LaserWriter 7.1.2 software is required to use the Tektronix driver with system 6.0.7. If you need this software, do the following steps:
 - a. Open the *Old System Items* folder on the Macintosh Driver and Printer Utilities diskette.
 - b. Drag the **Backgrounder V1.3** and **PrintMonitor V7.0** from the diskette to the **closed System Folder** icon on your Macintosh hard disk. At the alert message, click **OK** to automatically install these items in their proper places.
 - c. Restart your Macintosh to activate the software.
5. Select **Chooser** from the **Apple** menu.

6. Click the **Phaser 240** printer driver icon on the left side of the **Chooser**. A list appears with the printers you have connected to your Macintosh or printers that are available on a network. (If the printer driver icon does not appear, **Restart** your Macintosh, and repeat the printer driver installation procedure; also check the cable connections on your computer and printer.)
7. Click on your Phaser 240 printer in the list of printers on the right side of the **Chooser**.
8. Close the **Chooser** by clicking its close box.
9. Store the printer diskette in a safe place.

Installing the Phaser 240 GX driver

1. Make sure that your Macintosh is turned on with QuickDraw GX and System Software version 7.5 installed.
2. Insert the Macintosh Driver and Printer Utilities diskette into the disk drive.
3. When the diskette appears on the desktop, it should be open, showing the icons inside.
4. Drag the **Phaser 240 GX** driver icon from the diskette to the **closed System Folder** icon on your Macintosh hard disk. At the alert message, click **OK** to automatically install the driver in the *Extensions* folder.
5. Select **Chooser** from the **Apple** menu.
6. Click the **Phaser 240 GX** printer driver icon on the left side of the **Chooser**. A list appears with the printers you have connected to your Macintosh or printers that are available on a network. (If the printer driver icon does not appear, **Restart** your Macintosh, and repeat the printer driver installation procedure; also check the cable connections on your computer and printer.)
7. In the **Connect via** field's pop-up menu, select your printer's communication method:
 - The **AppleTalk** option is the standard network connection.
 - The **Servers** option is used to select a shared desktop printer. See the *Phaser 240 Drivers and Utilities Printing Reference* for details.

2 *Getting Set Up*

8. Click on your Phaser 240 in the list of printers on the right side of the **Chooser**.
9. Click the **Create** button to create a desktop printer. An icon of the printer appears on the desktop with the same name as the printer selected in the **Chooser**.
10. Close the **Chooser** by clicking its close box.
11. Store the printer diskette in a safe place.

Workstation users

The printer-control PostScript files that are on the Windows 3.1 Driver and Printer Utilities diskette (PC format) can be used with Unix and VMS workstations. These files let you set up your spooling system to select between media trays, print quality modes, color correction modes and other features. Unix workstation users can access utility files in the following ways:

- Mount the PC diskette on your workstation.
- Download utility files from the Tektronix Bulletin Board Service (BBS).
- Request utility files from the Tektronix Color Printer Information Server over the Internet.

Most workstations with 3.5-inch disk drives provide a device driver that allows you to mount a PC floppy diskette. Refer to the *Phaser 240 Drivers and Utilities Printing Reference* for information about mounting PC diskettes.

Refer to Chapter 6, “Troubleshooting,” for information about accessing Tektronix’ Bulletin Board Service or Color Printer Information Server.

Setting up PC ports (DOS)

Parallel port setup

If you are using the printer's parallel port, you should disable timeouts on your computer's parallel port. Disabling timeouts ensures that large files will print, even if data transmission is slow.

The DOS **MODE** command is used to disable timeouts on your computer's parallel port. Type this command at the DOS prompt (if LPT1 is not available, use LPT2):

```
MODE LPT1:,,P
```

See your DOS documentation for details on the **MODE** command.

You may want to add the **MODE** command to your *AUTOEXEC.BAT* file, so that it takes effect every time you turn on your computer.

Turning on and off the startup page

You can enable and disable the startup page by sending utility files from the printer's utilities diskette to the printer. For details on controlling the startup page, refer to the *Phaser 240 Drivers and Utilities Printing Reference*.

Even when the startup page is enabled, you can still keep it from printing by removing the paper tray(s) at power-up. Put the paper tray(s) back in after the **READY** light stops blinking.

What next?

- Once you have set up all the hardware and connectors, installed any options, installed the software on your computer, and turned on the power, you are ready to print. Chapter 3, "Printing," contains useful information on printing features such as color corrections, fonts, and printing hints. For detailed information on printing options, refer to *Phaser 240 Drivers and Utilities Printing Reference*.

2 *Getting Set Up*

Printing

Which computer?

You can print to your printer from any of the following computers, providing the printer has the appropriate interface port. Refer to “Printer ports” on page 2-14 for more information.

- PC — in Windows and in DOS
- Macintosh
- Unix and VMS Workstations

To print from a PC running Windows or from a Macintosh, you should have first installed a Tektronix driver for your computer. Tektronix printer drivers contain page size information and selections specifically for the type of media or tray being used with your printer. For information on installing the drivers, see “Installing a driver on your computer” on page 2-23. For detailed information on the drivers, refer to the *Phaser 240 Drivers and Utilities Printing Reference*. If you are printing from a PC running DOS, you must first set up the driver in your application software.

Use the following instructions to set up printing from your computer.

Printing from a PC (Windows)

1. Make sure that the Tektronix driver for Windows has been installed.
2. From the **File** menu, select the **Print Setup** command or the similar command in your application. Select the **Tek Phaser 240 (TekColor)** driver (the 17-font or 39-font version according to the installation you performed under “Microsoft Windows” on page 2-24) and select **Setup**. If you have previously set the printer as the default printer, it will already be selected on the list.
3. Use the **Setup** dialog box to select the paper size, paper source (**Upper tray**, **Lower tray**, or **Auto Select**), and other printing options.
4. Click on the **Options** button to display the **Options** dialog box.
 - a. Click on the **Printer Features** button to display the **Tektronix Printer Features** dialog box.
 - b. Use the **Tektronix Printer Features** dialog box to select TekColor color corrections and print quality.

If the **Printer Features** button does not appear in the **Options** dialog box, the Tektronix Windows driver probably is not installed or the printer has not been selected.

For details on the Tektronix driver, refer to the *Phaser 240 Drivers and Utilities Printing Reference*.

Printing from a PC (DOS)

1. In your application software, set up the printing options for a color printer driver. For more information on making these selections, refer to your application software's user manual.
2. Make sure that the PC communication ports have been set up correctly. Refer to "Setting up PC ports (DOS)" on page 2-34 for instructions.
3. Select the printer driver for the Phaser 240, a Tektronix Phaser printer, or a generic color PostScript driver.

Note *Generic PostScript printer drivers do not have information about your Phaser 240 printer, for example, its page sizes and its image area size. Using a standard Letter- or A4-size media selection should produce acceptable results.*

- a. Select the appropriate port (an LPT port for parallel or one of the network connections).
 - b. Set the page margins in your application software as needed. For details on the printer's paper and margin sizes, refer to "Margins and print area" on page 3-9.
4. Execute the application software's print command. Refer to the application software's user manual for details.

Printing from a Macintosh

The Macintosh Driver and Printer Utilities diskette includes two Macintosh printer drivers that allow you to select printer features.

Using the Phaser 240 driver

1. Install the Tektronix printer driver for the Macintosh if needed. Refer to “Macintosh users” on page 2-28 for instructions.
2. Select the driver in the **Chooser**.
3. To print a file, use the **Page Setup** and **Print** commands from the **File** menu within your application:
 - a. In the **Page Setup** dialog box, select the desired paper size from the pop-up menu so that the application uses the correct margins for the printer. To see the choices, use the pop-up menu to the right of the standard **Paper** sizes.
 - b. In the **Print** dialog box, click the **TekColor** button to open the **TekColor Options** dialog box, in which you can select the TekColor color corrections, print quality, and paper trays. For more details on the driver, refer to the *Phaser 240 Drivers and Utilities Printing Reference*.

Using the Phaser 240 GX driver

1. Install the Tektronix printer driver for the Macintosh if needed. Refer to “Macintosh users” on page 2-28 for instructions.
2. Select a desktop printer.
3. Print from the driver using one of the following methods:
 - **For QuickDraw GX applications**
Select the desktop printer you want to use, then use the **Print** dialog box (select **Print** from the **File** menu).
 - **For non-QuickDraw GX applications**
You can print to the *default* desktop printer from the **Print** dialog box (select **Print** from the **File** menu). To change the default desktop printer, select (highlight) the desktop printer you want to use, then select **Set Default Printer** from the **Printing** menu.

Refer to the *Phaser 240 Drivers and Utilities Printing Reference* for more information on using the Phaser 240 GX printer driver.

Printing from a Unix or VMS workstation

You can print from a workstation through Ethernet or parallel interfaces. Workstation users can print from any application that generates color PostScript.

For Unix and VMS environments, Tektronix offers Phaser Print. Phaser Print provides fast raster file and screen copy printing to Tektronix color printers. Phaser Print also provides a graphical user interface for push-button control of Tektronix printer features.

Phaser Print software is available for these workstations:

Workstation	Operating System
Sun	Sun OS 4.1.X, Solaris 2.X
SGI	IRIX 4.0.5 and 5.2
HP 9000 700/800	HPUX 9.X
IBM RS/6000	AIX 3.2
DECstation	Ultrix 4.X
DEC Alpha	OSF/1 1.3

Note *Tektronix offers a similar solution for DEC OpenVMS VAX and DEC OpenVMS AXP.*

Phaser Print works with the workstation's native spooling system to print PostScript files and raster files in these formats: Sun Raster Format (SRF), **xwd**, and SGI RGB.

If you ordered the TCP/IP Ethernet option for your printer, you received a demonstration copy of Phaser Print on a compact disk (CD). If you did not receive a demonstration CD but would like one, or if you would like to purchase a licensed version of Phaser Print, contact your dealer, local Tektronix office, or in the United States, call **1-800-835-6100**.

For VMS environments, Tektronix also offers PhaserSym, a VMS print symbiont. Refer to Appendix B for ordering information.

For information on printing from workstations and setting up spooling systems, you can contact HAL, the Tektronix automated fax system by calling direct **(503) 682-7450** or, in the United States or Canada, by calling toll-free **1-800-835-6100**. Refer to “Using the automated fax systems” on page 6-16 for details on using the HAL system.

For workstation users who prefer not to use Phaser Print, the printer-control PostScript files that are on the Windows 3.1 Driver and Printer Utilities diskette (PC format) can be used for Unix workstations. These files let you set up your spooling system to select between media trays, print quality modes, color correction modes and other features. Most workstations with 3.5-inch disk drives provide a device driver that allows you to mount a PC floppy diskette.

If you don't have the means of transferring utility files to control printer features from the PC diskette, you can download utilities and files from the Tektronix Bulletin Board Service (BBS) or request files from the Tektronix Color Printer Information Server, an automatic file serving program on the Internet. Refer to “Whom to call for help” on page 6-14 for information about accessing Tektronix' Bulletin Board Service or Color Printer Information Server.

Printing from specific applications

Refer to the *Phaser 240 Drivers and Utilities Printing Reference* for information on PostScript printer description files required by some applications.

In addition, you can get tips on printing from certain applications (such as QuarkXPress and PageMaker) by contacting HAL or EuroHAL, the Tektronix automated information systems. HAL and EuroHAL fax you information immediately on applications and other topics. To receive a HAL FAX catalog, call toll-free in the U.S. **1-800-835-6100** or dial direct, **(503) 682-7450**. For a EuroHAL catalog, use the telephone numbers provided in “Whom to call for help” on page 6-14. For more information on HAL and EuroHAL, see “Using the automated fax systems” on page 6-16.

Margins and print area

When the printer places an image on paper, the image is a bit smaller than the paper size. You may need to adjust the page margins in your application software to match the print area.

Perforated paper and transparencies

Use Tektronix perforated paper or transparencies and the Tektronix Phaser 240 driver to get the largest image areas. With Tektronix perforated paper or transparencies, you can print the largest area and tear off the excess at the perforation. This gives full A or A-4 Letter-size images within ISO margins.

This illustration shows the largest image areas for perforated paper and transparencies. All margins are 5 mm (0.2 in.). The bottom margin is 5 mm (0.2 in.) after the perforated area is removed.

1. American A-size (LETTER PERF)
2. Metric A4-size (A4 PERF)

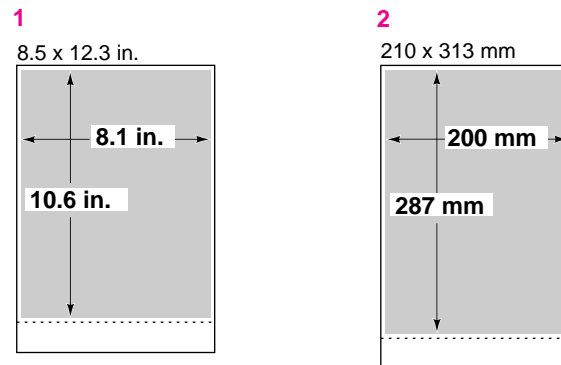

9238-20

Non-perforated plain paper

This illustration shows the largest image areas for non-perforated plain paper. All margins are 5 mm (0.2 in.), except the bottom margin (21 mm for A4-size, 0.83 in. for A-size).

Note *The standard trays supplied with the printer are for Tektronix perforated paper and transparencies; they are not adjustable for plain paper. Trays for plain paper must be ordered separately.*

1. American A-size (LETTER)
2. Metric A4-size (A4)

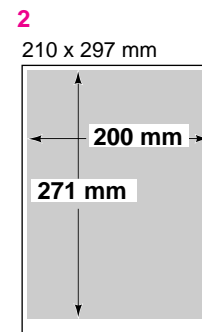
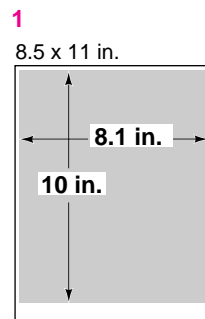

9238-21

Using two paper trays

Note *When using a printer with a Lower Tray Assembly, make sure that the door covering the upper slot is closed before you try to make a print from the lower tray. You cannot print from the lower tray with the door open.*

Recommended paper tray selections

Use	If
Upper or Lower tray	You use different media in each tray or different sizes in each tray. Some examples: <ul style="list-style-type: none"> ■ Paper in one tray and transparency in the other. ■ Standard paper in one tray and special letterhead in the other. ■ Perforated paper in one tray and non-perforated in the other.
Auto Select	You use the same media in both trays.

You can select the **Upper** or **Lower** tray by using a Tektronix Phaser 240 driver or utility files provided on the printer's utility diskettes. If you select the upper or lower tray by one of these methods, the printer will pick paper from the selected tray until the tray is empty. When the tray is empty, printing stops until the selected tray is filled.

You can also select **Auto Select** by using a Tektronix Phaser 240 driver or a utility file provided on the printer's utility diskettes. If you select **Auto Select** by one of these methods, the printer will pick paper from the tray that contains the selected paper size. When that tray is empty, the printer will automatically pick from the other tray if it also contains the selected media size.

Note *Paper tray selections made in the driver take priority over selections made by sending utility files to the printer.*

In all cases, you can change the printer's tray-switching behavior by sending the appropriate utility file to the printer. For more information, see the *Phaser 240 Drivers and Utilities Printing Reference*.

Selecting driver features

You can use the Phaser 240 drivers to select Phaser 240 features:

- Page sizes
- Paper trays
- Color corrections
- Print quality modes

For complete instructions on installing and using the Phaser 240 drivers, see the *Phaser 240 Drivers and Utilities Printing Reference*.

Print modes

You can select between the printer's print quality modes using a Phaser 240 printer driver or utility files provided on the Phaser 240 drivers and utilities diskettes. Refer to the *Phaser 240 Drivers and Utilities Printing Reference* for complete details.

- **Standard** mode is the default. It provides high-quality 300 x 300 dpi prints with the fastest print time.
- **Enhanced** mode provides improved 300 x 300 dpi prints; print time is increased by 10 seconds over **Standard** mode.
- **High Resolution** mode provides exceptionally high-quality 600 x 300 dpi prints. In **High Resolution** mode, image processing time is about 30% longer than with **Standard** mode. Also, the printer's *paper-marking* speed can be up to twice as long as **Standard** mode. (The paper-marking speed is the time it takes the printer to put the colored wax on the paper after it has processed the image).

Note *High Resolution print mode is only available when an 8- or 16- Mbyte memory option is installed.*

Color corrections

The default color correction for the Phaser 240 is Vivid Color. You can select between the printer's other TekColor color correction modes using a Phaser 240 printer driver or utility files provided on the Phaser 240 drivers and utilities diskettes. For complete information on color correction, refer to the *Phaser 240 Drivers and Utilities Printing Reference*.

If you are using TekColor Dynamic Correction in the Phaser 240 drivers, the settings you choose in the drivers override any color correction set by DIP Switches inside the printer's rear panel door. Refer to Chapter 7, "Front and Rear Panels," for more information on DIP Switches.

Note *The print driver help window provides a short description of each color correction mode. To access information, click on the **Help** button (for a Macintosh, in the **TekColor Options** dialog box; for Windows, in the **Tektronix Printer Features** dialog box).*

Fonts

Resident typefaces (PostScript)

The Phaser 240 supports 17 fonts in its standard configuration. An additional 22 fonts can be added by installing font upgrade kit 4681F1F.

1. Printer's resident typefaces.
2. Additional 22 resident typefaces available with a font SIMM provided in upgrade kit 4681F1F.

1

Courier
Courier Bold
Courier Oblique
Courier Bold Oblique

Helvetica
Helvetica Bold
Helvetica Oblique
Helvetica Bold Oblique

Helvetica Narrow
Helvetica Narrow Bold
Helvetica Narrow Oblique
Helvetica Narrow Bold Oblique

Times Roman
Times Bold
Times Italic
Times Bold Italic

Symbol (Σ ψ μ β ο λ)

2

ITC Avant Garde Gothic Book
ITC Avant Garde Gothic Book Oblique
ITC Avant Garde Gothic Demi
ITC Avant Garde Gothic Demi Oblique

ITC Bookman Light
ITC Bookman Light Italic
ITC Bookman Demi
ITC Bookman Demi Italic

Helvetica Condensed
Helvetica Condensed Bold
Helvetica Condensed Oblique
Helvetica Condensed Bold Oblique

New Century Schoolbook
New Century Schoolbook Bold
New Century Schoolbook Italic
New Century Schoolbook Bold Italic

Palatino
Palatino Italic
Palatino Bold
Palatino Bold Italic

ITC Zapf Chancery
 ITC Zapf Dingbats (☆ * ❖ ❖ ❖ ❖ ❖ ❖ ❖ ❖ ❖ ❖)

9238-22

Resident typefaces (PCL5)

For monochrome PCL5 (Printer Command Language) printing (HP LaserJet III emulation), the printer supports Courier, Times, and Univers typefaces in the following styles and stroke weights: medium, bold, italic medium, and bold italic.

Downloading fonts

The fonts resident in the printer are stored in the printer as outlines and are always available for printing. The PostScript interpreter in the printer can also accept and store additional fonts known as downloadable fonts. If you want to print PostScript outline fonts that are not built into the printer, you can transfer or download outline fonts from your computer to the printer. Downloading fonts saves print time if you plan to print several documents or a large document using those fonts.

When you download a font, it is stored in the printer's memory. You can download as many outline fonts as the printer's memory allows. Adding more memory expands the number of fonts that can be downloaded to the printer.

The printer accepts Type 1 and Type 3 downloadable fonts including those from Adobe, AGFA, Bitstream, Microsoft, Apple, and many others.

The printer also accepts TrueType downloadable fonts which can be scaled to any point size. TrueType fonts look the same on the screen as they do when printed.

You download a font from a PC or Macintosh the same way you download fonts to any PostScript printer. Follow the documentation that was shipped with your fonts.

Installing Macintosh screen fonts

The Phaser 240 Macintosh diskette includes screen fonts corresponding to the printer's fonts. If these screen fonts are not already installed on your system, you must install them if you want to see the printer's resident typefaces on the Macintosh screen. For information on how to install these screen fonts, see the *Phaser 240 Drivers and Utilities Printing Reference*.

Printer languages: PostScript, HP-GL, PCL5

With Adobe IntelliSelect™ technology, Phaser 240 printers automatically sense the language of the print job and process it accordingly. This is called *automatic language selection*. You can also set up any printer port to receive one language only. If you set up a port to receive a particular language only, the port will only accept jobs of that type. The printer reports an error if another language is sent to that port. For more information, see the *Phaser 240 Drivers and Utilities Printing Reference*.

The default language setting for all ports is PostScript.

Enabling and disabling automatic language switching

To enable or disable automatic language selection on a port, send the appropriate utility file to the printer. For more information, see the *Phaser 240 Drivers and Utilities Printing Reference*.

Printing hints

Getting the largest printed picture

Use the Tektronix Phaser 240 driver and perforated paper or transparencies to get the largest print areas. You may also have to adjust the margins in your application software.

Why should I use perforated paper?

By using Tektronix perforated paper (and transparencies), you can print full A-size or A4-size images with standard ISO margins (5 mm; 0.2 in.).

How long does it take to make a print?

The total print time depends on the image complexity, the type of port used, and the printer's paper-marking speed. The paper-marking speed is the time it takes the printer to put the colored wax on the paper, once it has received the processed image.

Of these three elements, only the printer's paper-marking speed is predictable; the others can vary greatly depending on your system configuration and the type of image you are printing. However, the Phaser 240 PostScript interpreter combines very fast image processing and communication with sophisticated memory management to keep the total print time to a minimum. For details on the printer's paper-marking speed, see "Specifications" on page A-3.

Caring for Your Printer

Overview

To ensure the best print quality and the most reliable printer operation, follow these two simple guidelines:

- Use *only* Tektronix transparencies and transfer rolls. When printing with a 3-Color or Black transfer roll, use *only* Tektronix thermal-transfer paper. When printing with a ColorCoat™ transfer roll on common laser paper, use paper that conforms to the guidelines given in “Recommended paper types” on page 5-4.
- Perform the regular cleaning described in this chapter.

Importance of cleaning

By performing regular cleaning, you can ensure that your printer produces the highest quality prints. Regular cleaning also helps prevent paper jams, smudged prints, skewed images, and misregistration. If you clean the printer at intervals listed under the next topic, “When to clean,” you will experience fewer paper problems, improved print quality, and less downtime.

Cleaning the printer is easy. Follow the cleaning procedures given in the next few pages, or use the *Cleaning Instructions* that come with each cleaning kit.

When to clean

Every time you replace the transfer roll, clean these printer parts:

- Thermal head and transfer roll guide
- Paper-feed rollers
- Paper-pick rollers

Clean these printer parts every 5,000 prints, or as needed to prevent smudging on prints:

- Transfer roll sensor pad
- Drum
- Exit rollers

A preventive check by a Tektronix field service representative is recommended every 10,000 prints or every year. The startup page and the configuration page report the number of prints made since the printer was shipped from Tektronix.

Cleaning kit

A cleaning kit comes with the printer. The cleaning kit contains these items:

- Lint-free cleaning wipes
- A plastic bottle for isopropyl alcohol
- A cleaning tray for cleaning paper-pick rollers
- Cleaning instructions (you may use those instructions, or follow the instructions in the next few pages)

For the cleaning kit that is shipped with the printer, you must supply isopropyl alcohol (available at pharmacies); shipping regulations prohibit supplying alcohol or presoaked cleaning materials with the printer.

In general, you should use the purest isopropyl alcohol available to you. 99% pure is best, and 90% also works well.

Caution *Do not use rubbing alcohol because it can contain water and oils that leave undesirable residue on the printer parts.*

Note *To order a new cleaning kit, call your dealer or Tektronix (order number 016-1233-00). You can also order a cleaning kit containing presoaked alcohol cleaning wipes (order number 016-1276-00).*

Cleaning the printer (with every transfer roll change)

Perform the next three cleaning procedures every time you replace the transfer roll.

Note Turn off the printer before cleaning the thermal head and the paper-feed rollers. The printer must be turned on to clean the paper-pick rollers.

Cleaning the thermal head and transfer roll guide

1. Press the button to open the top cover. Dampen a lint-free cleaning wipe with isopropyl alcohol.
2. Wipe the full width of the thermal head several times. Remove any dust, dirt, and wax.
3. Wipe the full width of the transfer roll guide several times. Close the top cover when you are finished.

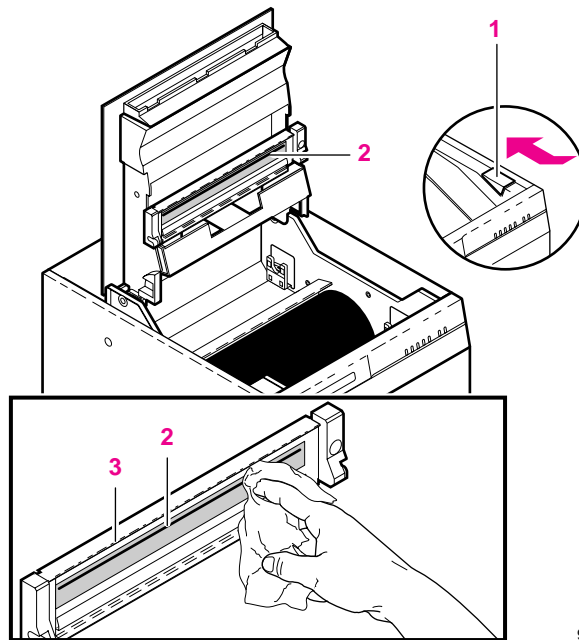

9238-23

Cleaning the paper-feed rollers

Caution *Be careful not to scratch the curved plastic parts inside the front cover. Scratches in this area could cause paper jams.*

1. Slide out the front cover and remove it. Dampen a lint-free cleaning wipe with isopropyl alcohol.
2. Wipe the paper-feed rollers. Be sure to clean all three rollers. It is not necessary to move the rollers as you clean them; clean only the exposed surface of the rollers.
3. Slide the front cover back into place.

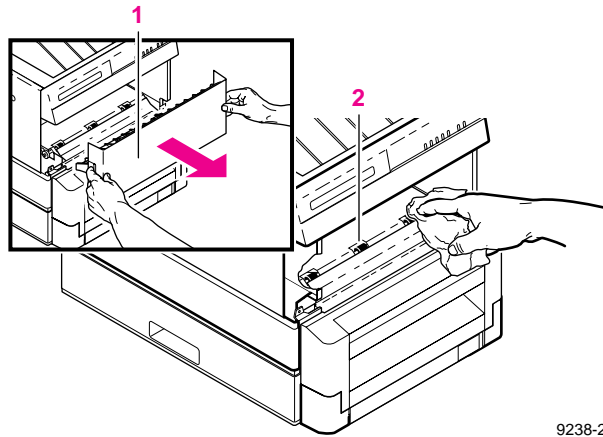

9238-24

Cleaning the paper-pick rollers

Make sure that the transfer roll is installed before you begin this cleaning procedure.

To clean the paper-pick rollers, you must use the cleaning tray from the cleaning kit.

1. Turn the printer off, then on again.
2. Remove the paper tray(s), and remove the paper or transparencies from one of the trays.

When removing paper or transparencies, do not push the paper tray's metal plate down. (If the metal plate is down, put the paper tray into the slot and pull it out; this returns the metal plate to the up position.)

3. If you are using an A4-size (metric) paper tray, break off the tabs on the sides of the cleaning tray. The allows the cleaning tray to fit into the metric paper tray. **Do not break off the tabs if you are using an A-size (U.S.) paper tray.**

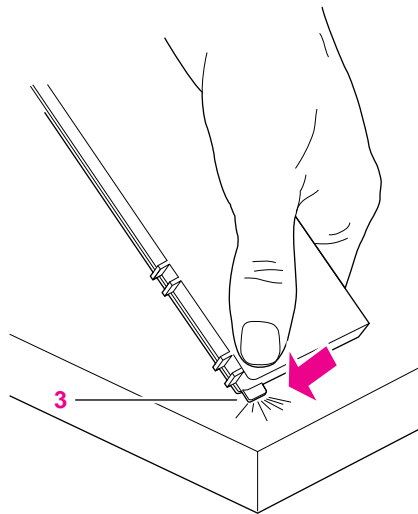

9238-25

4. Open the cleaning tray.
5. Dampen the pad on the cleaning tray with isopropyl alcohol. Dampen the entire surface of the pad.
6. Slide the cleaning tray into the paper tray. As you slide the cleaning tray into position, press down the paper tray's metal plate slightly. When the cleaning tray is properly installed, the paper tray's metal plate presses up against the cleaning tray, holding it in place.
7. Make sure that the flanges on the front of the cleaning tray overlap the front of the metal plate.

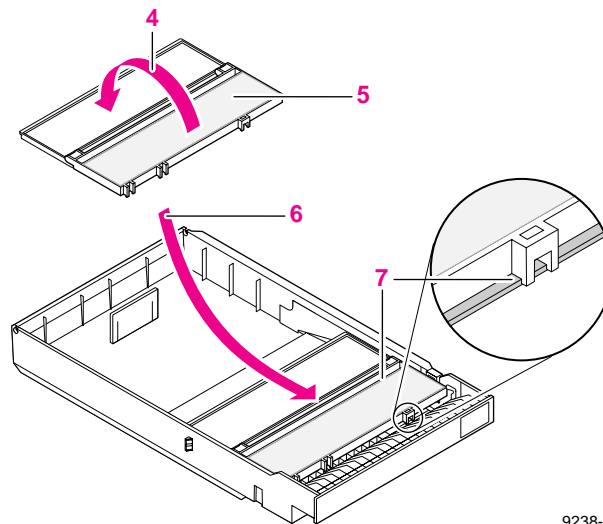

9238-26

8. Slide the paper tray (containing the cleaning tray) into the slot. If your printer has a Lower Tray Assembly, slide the tray into the **lower** slot.
9. Press the **TEST** button on the back of the printer for 3 seconds. The printer attempts to load paper, bringing the paper-pick rollers in contact with the alcohol-dampened pad in the cleaning tray.
10. The **JAM** indicator blinks, indicating that the rollers have been cleaned.
 - a. If your printer has a single paper tray, the procedure is complete. Slide out the paper tray, remove the cleaning tray, and replace the paper or transparencies. Slide the paper tray back into the slot. If paper-picking problems occur, repeat this cleaning procedure.
 - b. If your printer has a Lower Tray Assembly, pull out the paper tray a few inches and then push it back in to clear the **JAM** indicator. Then perform the steps on the next page to complete the procedure.

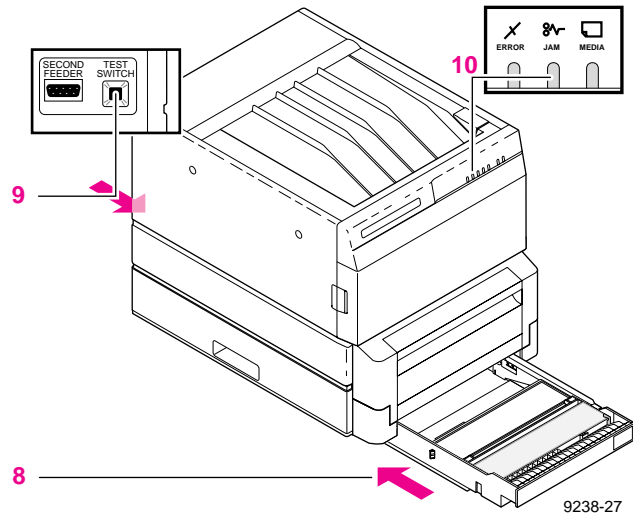

To complete the paper-pick roller cleaning for printers with a Lower Tray Assembly:

1. Remove the paper tray (containing the cleaning tray) from the lower slot. Dampen the pad on the cleaning tray again.
2. Insert the paper tray (containing the cleaning tray) into the upper slot. (Leave the lower slot empty for now.)
3. Press the **TEST** button on the back of the printer for 3 seconds. Again, the printer attempts to load paper, bringing the paper-pick rollers in contact with the alcohol-dampened pad in the cleaning tray.
4. The **JAM** indicator blinks, indicating that the rollers have been cleaned.
5. Pull out the paper tray. Remove the cleaning tray from the paper tray, and replace the paper or transparencies. Put both paper trays back into their slots.

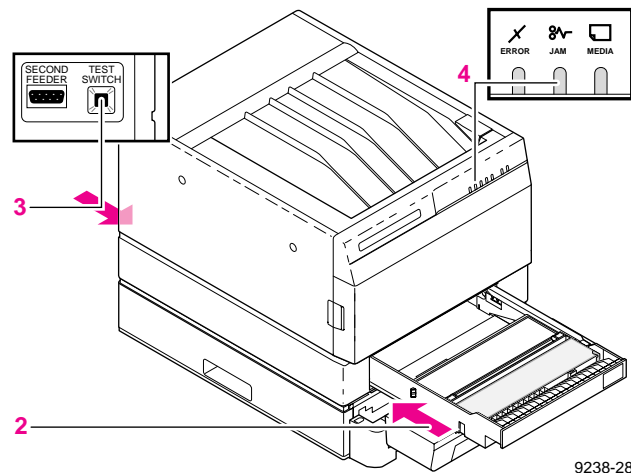

Cleaning the printer (every 5,000 prints)

Perform the next three procedures every 5,000 prints.

Note *Turn off the printer before performing the next three cleaning procedures.*

Cleaning the transfer roll sensor pad

1. Press the button to open the top cover.
2. Remove the transfer roll.

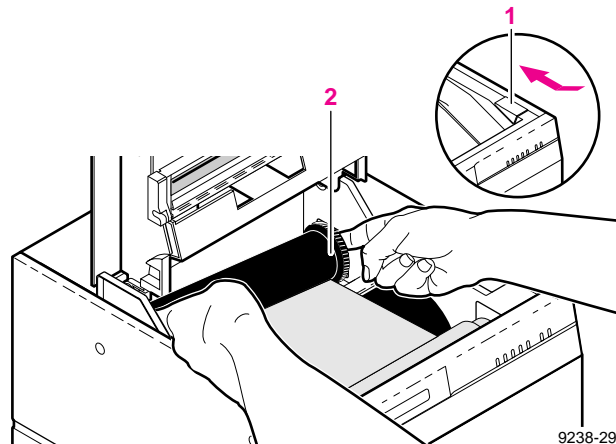

9238-29

3. Dampen a lint-free cleaning wipe with isopropyl alcohol. Wipe the transfer roll sensor.
4. Leave the transfer roll out and the top cover open. Go on to the next procedure.

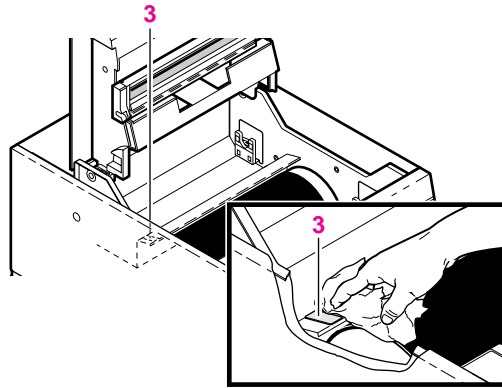

9238-30

Cleaning the drum

1. To clean the drum, you must have the top cover open and the transfer roll removed.
2. Dampen a lint-free cleaning wipe with isopropyl alcohol. Wipe the drum. Move the drum toward the front of the printer to access the entire surface of the drum as you clean.
3. When the alcohol on the drum is dry, put the transfer roll back into the printer and close the top cover.

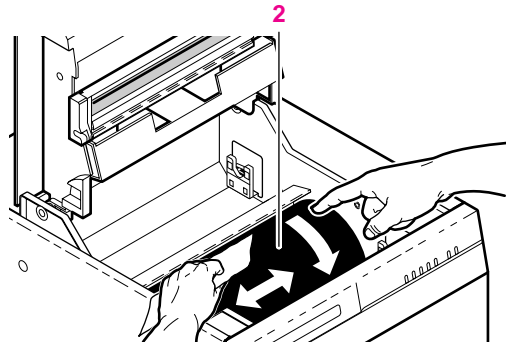

9238-31

Cleaning the exit rollers

1. Slide out the front cover and remove it.
2. Dampen a lint-free cleaning wipe with isopropyl alcohol. Wipe the exit-feed rollers. Be sure to clean all three rollers. It is not necessary to move the rollers as you clean; clean only the exposed surface of the rollers.
3. Replace the front cover.

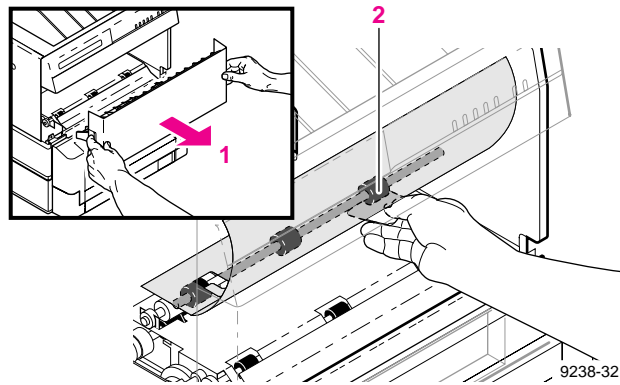

4 *Caring for Your Printer*

Selecting Media and Image Options

This chapter explains how to do the following tasks:

- Selecting media size
- Selecting media trays
- Selecting print quality
- Selecting image orientation
- Selecting media type

Selecting media size

The **Paper** (Macintosh) or **Paper Size** (Windows) options in the Tektronix drivers let you choose the paper size you want to print on. The drivers support both U.S. and metric media sizes. The default is **Letter** (8.5 x 11 inches).

Refer to your *Phaser 240 Color Printer User Manual* for information on loading the media trays.

Phaser 240 special paper sizes

Paper sizes	Dimensions	Image area
Letter	8.5 x 11 ins.	8.1 x 9.96 ins.
Letter Perf	8.5 x 12.3 ins.	8.1 x 10.61 ins.
A4	210 x 297 mm	200 x 271 mm
A4 Perf	210 x 313 mm	200 x 287 mm

- 1. Letter-size media
- 2. A4-size media

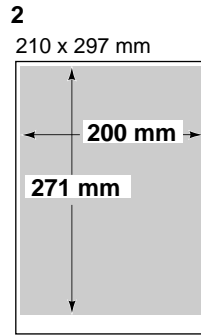
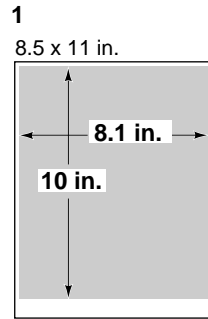

9243-03

- 1. Letter Perf-size media
- 2. A4 Perf-size media

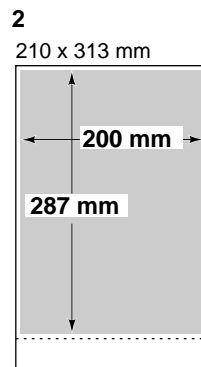

9243-02

Phaser 240 Macintosh driver (based on LaserWriter 7.1.2)

The **Paper** options are in the **Page Setup** dialog box. The first four selections are the standard LaserWriter paper sizes (US Letter, US Legal, A4 Letter, and B5 Letter). The fifth **Paper** option field is a pop-up menu with special Tektronix paper sizes.

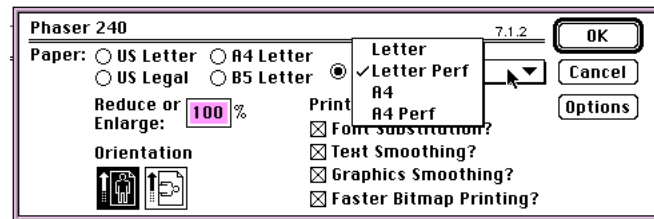

The printer's maximum image area is not available with the standard LaserWriter paper sizes; use the Tektronix page sizes in the pop-up menu to print the maximum image area. Refer to the table on page 5-2 for image area information. Refer to your Apple documentation for details on the other LaserWriter driver features in this dialog box.

Some applications override the Tektronix page sizes with their own extensions to this dialog box. These application-specific page sizes use page size and image area information about the Tektronix printer from the printer description files. Refer to “Printing from an application” on page 2-19 for information on these files.

Phaser 240 GX Macintosh driver

The **Paper** options are in the **Page Setup** dialog box.

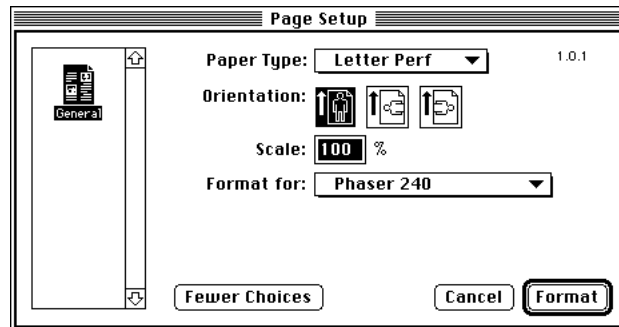

Tektronix driver for Windows 3.1

The **Paper Size** options are in the **Printer Setup** dialog box.

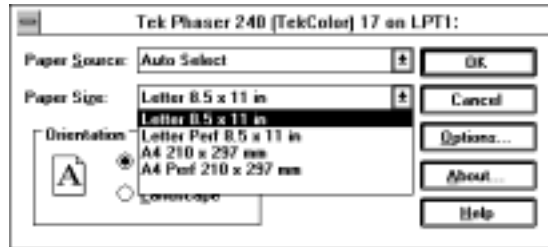

All paper sizes listed may not be available for every Windows application. For example, Excel 3.0 can print only on the paper sizes listed in its own **Page Setup** dialog box.

In some Windows applications, you can select printer page sizes in a **Print Setup** dialog box accessed from the **File** menu. If you use a **Print Setup** dialog box to select the Phaser 240 from your application, some page sizes may not be visible in the list. If the Phaser 240 page size you want to use is not visible in the list, see “Selecting page sizes in Windows applications” on page 8-20 for more information.

Selecting media trays

If your printer has the optional lower tray assembly, use one of the methods in the following table to select a media tray.

Options	Tektronix driver settings	Downloadable utility files
Use the upper media tray	✓	✓
Use the lower media tray	✓	✓
Automatically switch between media trays	✓	✓

The Phaser 240 printer comes standard with one perforated-paper tray for metric or U.S. paper sizes. A lower tray assembly can be added and other tray types can be used (call the Tektronix Graphics Supplies Order Desk at 1-800-835-6100).

Note *Selecting a tray from a driver overrides a downloaded utility file for prints made from the driver.*

- **Upper Tray**

Paper or transparency film is automatically loaded from the upper tray. The printer picks media from the upper tray until the tray is empty. When the tray is empty, printing stops until the tray is refilled. Use this selection if you use different media in each tray.

- **Lower Tray**

Paper or transparency film is automatically loaded from the lower tray. The printer picks media from the lower tray until the tray is empty. When the tray is empty, printing stops until the tray is refilled. Use this selection if you use different media in each tray.

- **Auto Select**

If both trays contain the same size and type of media, media is automatically loaded first from the lower tray, and then from the upper tray when the lower tray is empty. Use this selection if you have the same size and type of media in both trays.

Different ways of selecting media trays

Method	Computer	Location	Selections
Tektronix printer drivers	Macintosh	<p>Phaser 240 driver:</p> <p>The Tray Selection options are in the TekColor Options dialog box.</p> <p>See page 2-6 for instructions.</p> <hr/> <p>Phaser 240 GX driver:</p> <p>The Tray Selection options are in the TekColor printing extension.</p> <p>See page A-19 for instructions.</p>	<ul style="list-style-type: none"> ■ Upper ■ Lower ■ AutoSelect
	Windows 3.1	<p>Tektronix Phaser 240 driver for Windows 3.1:</p> <p>The Paper Source options are in the Setup dialog box.</p> <p>See page 3-11 for instructions.</p>	<ul style="list-style-type: none"> ■ Upper Tray ■ Lower Tray ■ Auto Select
Downloadable utility files	Macintosh	<p>All Macintosh users:</p> <p>Use the <i>LaserWriter Utility</i> to download these files to the printer.</p> <p>See page 2-14 for instructions.</p> <hr/> <p>QuickDraw GX users:</p> <p>Use Tektronix Phaser 240 GX driver to download these files to the printer.</p> <p>See page A-11 for instructions.</p>	<ul style="list-style-type: none"> ■ <i>Use Upper Tray</i> ■ <i>Use Lower Tray</i> ■ <i>Use Any Tray</i>
	PC/workstation	<p>Use the DOS COPY command to download these files to the printer.</p> <p>See page 3-19 for instructions.</p> <hr/> <p>Use the Windows File Manager to download these files to the printer.</p> <p>See page 3-20 for instructions.</p>	<ul style="list-style-type: none"> ■ <i>UPPRTRAY.PS</i> ■ <i>LOWRTRAY.PS</i> ■ <i>ANYTRAY.PS</i>

Selecting print quality

Use one of the methods in the following table to select a print quality option.

Options	Tektronix driver settings	Downloadable utility files
Print in the Standard print quality mode	✓	✓
Print in the Enhanced print quality mode	✓	✓
Print in the High Resolution print quality mode	✓	✓

The print modes affect the quality of printed images and the time they take to print. The higher quality modes, **High Resolution** and **Enhanced**, take longer to print than **Standard** mode.

- **Standard**

This is the fastest full-color mode and is useful for many applications. The **Standard** mode prints at a resolution of 300 x 300 dpi and is the default print quality mode.

- **Enhanced**

This mode produces higher quality prints than **Standard** mode. The **Enhanced** mode prints at a resolution of 300 x 300 dpi.

- **High Resolution**

This mode produces the best quality prints, but at the expense of processing and print time. The **High Resolution** mode prints a page at a resolution of 600 x 300 dpi.

This mode requires a minimum memory upgrade of 8 Mbytes, for a minimum total of 13 Mbytes in the printer. Refer to the *Phaser 240 Color Printer User Manual* for ordering information.

Different ways of selecting print quality

Method	Computer	Location	Selections
Tektronix printer drivers	Macintosh	<p>Phaser 240 driver:</p> <p>The Print Quality options are in the TekColor Options dialog box.</p> <p>See page 2-6 for instructions.</p> <hr/> <p>Phaser 240 GX driver:</p> <p>The Print Quality options are in the TekColor printing extension.</p> <p>See page A-19 for instructions.</p>	<ul style="list-style-type: none"> ■ Standard ■ Enhanced ■ High Resolution
	Windows 3.1	<p>Tektronix Phaser 240 driver for Windows 3.1:</p> <p>The Print Quality options are in the Tektronix Printer Features dialog box.</p> <p>See page 3-11 for instructions.</p>	<ul style="list-style-type: none"> ■ Standard ■ Enhanced ■ High Resolution
Downloadable utility files	Macintosh	<p>All Macintosh users:</p> <p>Use the <i>LaserWriter Utility</i> to download these files to the printer.</p> <p>See page 2-14 for instructions.</p> <hr/> <p>QuickDraw GX users:</p> <p>Use Tektronix Phaser 240 GX driver to download these files to the printer.</p> <p>See page A-11 for instructions.</p>	<ul style="list-style-type: none"> ■ <i>Standard Quality</i> ■ <i>Enhanced Quality</i> ■ <i>High Resolution</i>
	PC/workstation	<p>Use the DOS COPY command to download these files to the printer.</p> <p>See page 3-19 for instructions.</p> <hr/> <p>Use the Windows File Manager to download these files to the printer.</p> <p>See page 3-20 for instructions.</p>	<ul style="list-style-type: none"> ■ <i>STANDARD.PS</i> ■ <i>ENHANCED.PS</i> ■ <i>HIGHRES.PS</i>

Selecting image orientation

The **Orientation** option in the Tektronix Macintosh and Windows printer drivers lets you choose the direction your document is placed on the paper. Refer to your *Phaser 240 Color Printer User Manual* for more information on image placement and paper loading.

Select the orientation option you want for your prints.

- **Portrait:** Places your image vertically on the media.
- **Landscape:** Places your image horizontally on the media.

Phaser 240 Macintosh driver (LaserWriter 7.1.2-based)

The **Orientation** option is in the **Page Setup** dialog box.

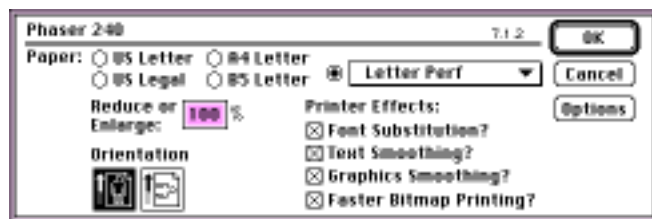

Phaser 240 GX Macintosh driver

The **Orientation** option is in the **Page Setup** dialog box.

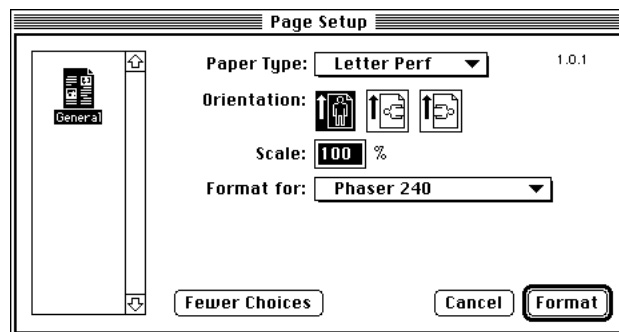

Tektronix driver for Windows 3.1

The **Orientation** option is in the **Setup** dialog box.

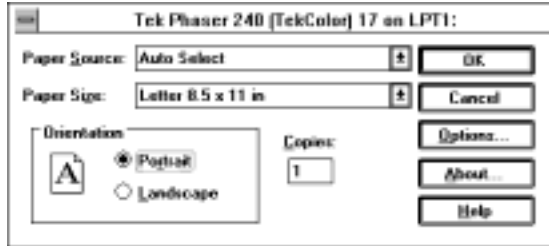

Selecting media type

The paper tray for perforated media (which comes standard with the printer) has a selection switch that you must set for paper or transparencies. As you hold the tray for insertion into the printer, locate the media switch on the tray's right side (1). Set the switch to match the type of media in the tray — push *up* for transparencies or push *down* for paper.

Note *The optional Letter and A4 trays have no switch; they are set for paper only.*

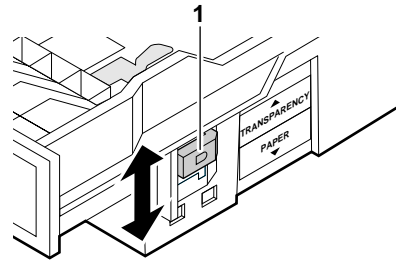

9243-01

Using Color

TekColor Dynamic Correction

This chapter explains how to select colors and how to make color corrections on your prints. Also included are instructions for printing and using the color sampler charts provided on the diskettes shipped with the printer.

The TekColor color corrections provide simulations of different color devices:

- Vivid Color for typical business and office printing.
- Simulate Display for engineering and scientific imaging applications.
- Simulate Press for graphic arts use.

Color corrections can be made in two ways:

- By selecting driver options from Macintosh and Windows applications using the Tektronix printer drivers.
- By using downloadable utility files.

Note *TekColor color corrections do not affect colors specified in the PostScript Level 2 international color standard CIE XYZ developed by the Commission Internationale de l'Eclairage (International Commission on Illumination).*

Working with color

You probably purchased your color printer with some idea of how you wanted to use color in your work. Whether you are producing color reports, memos, graphs, charts, overhead transparencies for presentations, color handouts, or design comps, there are a few things to keep in mind when using color.

- A large area of color looks more saturated (brighter) than a small area of the same color.
- A color looks brighter against a dark background than it does against a light background.
- Colors look different due to the background color or to the surrounding colors.
- The appearance of a color varies with the type and amount of light, for example fluorescent lighting versus sunlight.

General guidelines

- Keep color choices simple and consistent.
- Select colors that look good together and that reinforce your message.
- Check your application for standard palettes to get you started.
- Use a color scheme of five or six shades, and in a series of images, use the colors in a consistent manner throughout the series.
- Use color to highlight the most important information, such as a bar or pie segment in a chart or graph.
- Use color to show relationships between objects, such as a range of values. Objects with a similar meaning or value should be in similar colors.
- Use color as graphic elements in the design of newsletters, logos, and brochures.
- Avoid red and green combinations; these colors are hard for people with red/green color blindness to distinguish.

Using color in presentations

When used consistently, color in your presentations will help your audience remember key points. For example, graphics that represent your product should always appear in the same color. If you represent data graphically, be sure to put the most important data in red or the brightest, warmest color in your selected palette. Put the data you do not want to emphasize in cool colors.

Color design guidelines:

- Keep it simple; use up to seven colors maximum.
- Use color to indicate related elements.
- Use complementary colors for basic color schemes; use split complements for more subtle effects.
- Avoid blue/red and yellow/purple combinations.
- Use full-strength warm colors sparingly for emphasis.
- Use a cool, dark background color that won't compete with the foreground. Use foreground colors that stand out clearly against the background. Research shows that blue is the most preferred background color, followed by black, gray, brown, red, green, and purple.

Text and font guidelines:

- For readability, use dark text on a lighter background, or light text on a darker background. For example, white or yellow text with a deep blue background.
- Make text bold for emphasis.
- Text sizes on overhead transparencies or slides:
 - Use a 40-point or larger font for titles.
 - Use 24- to 36-point fonts for body text.
 - Use 5 to 7 lines of text *maximum* per slide or overhead.

Using color corrections

Color printers and computer display screens produce color differently. Printers use the subtractive primaries CMYK (cyan, magenta, yellow, and black), and produce color when light is reflected off the paper. Computers use the additive primaries RGB (red, green, blue) with a light-emitting CRT screen. The printer and the computer screen each have a different range of possible colors they can produce, with some overlap between them.

Software application packages specify color in different ways, for example as CMYK or RGB, or they may give you a choice. Get to know your applications so you can use color more effectively.

The TekColor color correction options are available for a finer degree of control over color. Since no single color correction option can address all uses, refer to the following table for the description that best fits your printing situation, and try the suggested color correction.

Printing objective or problem	Color correction to use	Where to find details
Brightest, most vibrant colors	Vivid Color	page 6-10
Overhead transparency presentations	Vivid Color	page 6-10
Blue colors are printing too purple	Vivid Color	page 6-10
Using PANTONE Colors	None	page 6-10
Colors should match computer display screen	Simulate Display	page 6-11
Colors should match a printing press	Simulate Press	page 6-11
Colors are too dark	Simulate Display	page 6-11
Colors are washed out or faded	Vivid Color	page 6-10
Print in gray scale	Monochrome	page 6-12

Color corrections table

Options	Tektronix driver settings	Downloadable utility files*
None (turn off all color corrections)	✓	✓
Vivid Color** (print the brightest colors, and a truer blue)	✓	✓
Simulate Display (simulate display screen colors)	✓	✓
Simulate Press (closely match printing press colors)	✓	✓
Monochrome (print in gray scale)	✓	✓
Use Printer Setting (use the current color correction setting in the printer's memory)	✓	n/a
Raw CMYK	n/a	✓
Raw RGB (use simple color conversions)	n/a	✓

* Downloadable utility files operate only in conjunction with the printer's switches; see page 6-8 for details.

** Vivid Color is also available with a printer switch; see page 6-8 for details.

n/a = This option is not available in this format.

Different ways of selecting color corrections

Method	Computer	Location	Selections
Tektronix printer drivers	Macintosh	<p>Phaser 240 driver:</p> <p>The Color Correction options are in the TekColor Options dialog box.</p> <p>See page 2-6 for instructions.</p> <hr/> <p>Phaser 240 GX driver:</p> <p>The Color Correction options are in the TekColor printing extension.</p> <p>See page A-19 for instructions.</p>	<ul style="list-style-type: none"> ■ None ■ Vivid Color ■ Simulate Display ■ Simulate Press ■ Monochrome ■ Use Printer Setting
	Windows 3.1	<p>Tektronix Phaser 240 driver for Windows 3.1:</p> <p>The Color Correction options are in the Tektronix Printer Features dialog box.</p> <p>See page 3-11 for instructions.</p>	
Downloadable utility files	Macintosh	<p>All Macintosh users:</p> <p>Use the <i>LaserWriter Utility</i> to download these files to the printer.</p> <p>See page 2-14 for instructions.</p> <hr/> <p>QuickDraw GX users:</p> <p>Use Tektronix Phaser 240 GX driver to download these files to the printer.</p> <p>See page A-11 for instructions.</p>	<ul style="list-style-type: none"> ■ No Color Correction ■ Vivid Color ■ Simulate Display ■ Simulate Press ■ Monochrome ■ Raw CMYK ■ Raw RGB
	PC/workstation	<p>Use the DOS COPY command to download these files to the printer.</p> <p>See page 3-19 for instructions.</p> <hr/> <p>Use the Windows File Manager to download these files to the printer.</p> <p>See page 3-20 for instructions.</p>	<ul style="list-style-type: none"> ■ <i>SIMPRESS.PS</i> ■ <i>DISPLAY.PS</i> ■ <i>MONOCHRM.PS</i> ■ <i>NOCORECT.PS</i> ■ <i>RAWCMYK.PS</i> ■ <i>RAWRGB.PS</i> ■ <i>VIVDCOLR.PS</i>

* Downloadable utility files operate only in conjunction with the printer's switches; see page 6-8 for details.

Using a Tektronix driver for selecting color corrections

Install a Phaser 240 driver according to the type of computer you are using:

- Macintosh Phaser 240 driver, for System Software 6.0.7, and 7.0 and higher; see page 2-2 for installation instructions.
- Macintosh Phaser 240 GX driver, for QuickDraw GX and System 7.5; see page A-2 for installation instructions.
- Phaser 240 driver for Windows 3.1; see page 3-3 for installation instructions.

A color correction setting made in the driver *always* overrides a downloaded utility file setting for prints made from the driver. However, the driver's **Use Printer Setting** option allows you to use the current downloaded utility file in the printer's memory.

Using downloadable utility files for selecting color corrections

If you are not using a Tektronix Phaser 240 driver, use the downloadable utility files to make color correction settings. Refer to the table on page 6-6 for information on locating downloading instructions for your computer type.

The color correction utility files operate only in conjunction with the printer's DIP switches.

Note *You shouldn't have to adjust the printer's switches. The following switch positions are the printer's factory default settings. However, if you think the printer's switches may have been adjusted, see your system administrator for information.*

For a downloaded color correction utility file to take effect, the printer's switches *must* be in the following positions *before* a utility file is downloaded to the printer:

- Switches 1, 2, and 4 *down*
- Switch 3 *up*

If you have to adjust the switches: The printer's switches are located inside the rear panel door. Refer to the *Phaser 240 Color Printer User Manual* for instructions on locating the printer's switches.

Other characteristics of printer switches:

- When shipped from the factory, the printer is set with Switch 3 *up*, enabling the Vivid Color selection. Later, if you download a color correction utility file to the printer, a new setting takes affect.
- If Switch 3 is placed in the *down* position, all color corrections are turned off, and no color correction utility files can be downloaded.
- If Switch 3 is placed in the *up* position again, then the last known color correction takes affect, such as a downloaded utility file if one had previously been sent to the printer.

If your Phaser 240 printer is shared by other users on a network

Another user may use the downloadable color correction utility files to change the printer's default color correction setting. If this situation occurs, the prints you make with a Phaser 240 driver's **Use Printer Setting** option, or with a non-Tektronix driver, may not print as expected. Refer to "Sharing the printer on a network" on page 8-21 for details on how the color correction utility files interact with the driver settings for either Tektronix or non-Tektronix drivers.

Application color corrections

Some applications perform color corrections to improve screen-to-printer color matching. The color correction options in the Tektronix drivers or utility files adjust colors in the printer after the application has performed its color corrections.

- If the application uses CIE (Commission Internationale de l'Eclairage) colors, the Tektronix corrections are not applied.
- If you select a color correction option in the driver other than **None**, the selection may override some application features.
- If you try one of the driver's other options and the printed results are not what you expected, then select the **None** option and try reprinting your image.

Turning off all color corrections

If you do not want to use any Tektronix color corrections, you can specify no corrections from a Tektronix driver or with utility files. Select no corrections when you are using applications that do their own color adjusting.

Printing the brightest colors and a truer blue

The **Vivid Color** option is the best choice for typical office printing. This option also makes printed blue appear less purple by reducing the amount of magenta used to print blue colors. Other colors in the cyan-blue-purple-magenta range in the image are also adjusted to compensate for the adjusted blue. Colors in the red-orange-yellow-green range are not affected. This selection is good for making presentation graphics, such as overhead transparencies, and for bright-looking colors that don't need to match the screen's colors or printing press colors.

Vivid Color adjusts CMYK colors using a method that adds black to other components. This option prints more saturated (darker) colors and may be useful for printing overhead transparencies for presentations from some applications, such as CorelDRAW!. Use this option if you have specified a color in the CMYK system, *and* the color has a black component, *and* the color appears lighter than you expected when printed.

Simulating display screen colors

The **Simulate Display** option makes printed colors approximate the colors on a standard display screen. This selection should improve the screen-to-printer color accuracy for most applications that don't perform their own color corrections. This selection is best for applications that define colors as *RGB* (red, green, blue), *HLS* (hue, lightness, saturation), or *HSB* (hue, saturation, brightness).

Closely match printing press colors

Use the **Simulate Press** option if you are previewing work for a four color job to be printed on a printing press. This option simulates a four-color commercial printing press, *not* solid spot colors, such as PANTONE Colors.

Note *If you are selecting Phaser 240-specific PANTONE Colors in your application, use the **None** option; see page 6-10 for details. Also, use the **None** option with other color management systems, such as EfiColor.*

Printing in gray scale

The **Monochrome** option prints your color image as a monochrome gray scale (shades of gray between black and white). Use this option to print page masters for photocopying in black-and-white.

Using the printer's current color setting

The **Use Printer Setting** option is available only in the Tektronix Macintosh and Windows drivers. This option sends no color correction information to the printer. It uses the current setting in the printer to process colors for printing. The printer's setting can be one of the color correction utility files sent to the printer.

Use simple color conversions

The following utility files use Adobe's standard color conversions to tell the printer what type of output device you want it to simulate:

- *Raw CMYK Colors (RAWCMYK.PS)*: Converts all colors (CMYK, RGB, grays) to CMYK colors. Use this file if your application specifies colors as CMYK (cyan, magenta, yellow, and black). This file lets you control the CMYK output of the printer's colors without any TekColor color corrections.
- *Raw RGB Colors (RAWRGB.PS)*: Converts all colors (CMY, CMYK, grays) to RGB colors. Use this file if your application specifies colors as RGB (red, green, and blue). This file lets you control the CMY output of the printer's colors without any TekColor color corrections.

Printing the color sampler charts

You can select colors within an application using color component values. Which color chart you print and use depends on how the application you are using selects color. Refer to the application's documentation for information on color selection, then print one of the charts listed in the table below.

- The Macintosh files are located in the compressed *Phaser 240 Samplers.sea* archive file on the Macintosh Driver and Printer Utilities diskette; refer to page 2-13 for decompressing instructions.
- The PC files are located in the *SAMPLERS* directory on the Windows 3.1 Driver and Printer Utilities diskette.

Color sampler chart files

Color sampler chart	Number of printed pages	Macintosh file name	PC file name
Print a sample of CMYK colors	18	<i>CMYK Sampler</i>	<i>CMYK.PS</i>
Print a sample of RGB colors	12	<i>RGB Sampler</i>	<i>RGB.PS</i>
Print a sample of HSB colors	12	<i>HSB Sampler</i>	<i>HSB.PS</i>
Print a sample of Pantone Colors	46	<i>PANTONE-Tek Phaser 240</i>	<i>PANT240.PS</i>

The color sampler charts are made up of areas of color with each color's components listed below it. Each color sampler chart is several pages long; they are printed in panels that can be connected to form a wall chart or placed in a binder for easy reference.

Illustration

Before you print the CMYK, RGB, and HSB color charts

To match colors on the charts to colors selected within an application, use the same printer color correction to print the charts that you are going to use when selecting and printing those colors within an application.

Different options, such as color correction, print quality, paper type, and transfer roll type, affect the way the colors on the sampler charts look when printed. Before printing a color chart, select the combination of options you use most often, then use those same options later when printing the colors from within an application. Make a selection from each column in the following table, and write the combination of options on the printed chart for future reference.

For example, if you are printing from an application with the driver's **Vivid Color** and **Enhanced** options selected, then print the color chart with the *Vivid Color (VIVDCOLR.PS)* and *Enhanced Quality (ENHANCED.PS)* utility files downloaded to the printer. Or, if you are not using a Tektronix driver, use the same downloaded utility file to print the chart and to print the colors from an application.

Color Correction	Print Quality	Paper type/Transfer Roll type
<ul style="list-style-type: none"> ■ None ■ Simulate Display ■ Simulate Press ■ Use Printer Setting ■ Vivid Color 	<ul style="list-style-type: none"> ■ Standard Quality ■ Enhanced Quality ■ High Resolution 	<ul style="list-style-type: none"> ■ Plain paper/ColorCoat™ transfer roll ■ Thermal transfer paper/thermal-wax transfer roll

Printing and using the CMYK, RGB, and HSB color charts

Macintosh users

1. Follow the instructions on page 2-13 to decompress the *Phaser 240 Samplers.sea* and *Phaser 240 Utilities.sea* archive files from the Macintosh Driver and Printer Utilities diskette to your computer's hard disk.
2. Make sure the printer is loaded with the type of paper and transfer roll you want to use for printing the chart.
3. Select the appropriate printer in the **Chooser**.
4. Select a color correction from the following table:

Macintosh color correction utility file	Notes
<ul style="list-style-type: none"> ■ <i>Simulate Display</i> ■ <i>Vivid Color</i> ■ <i>Simulate Press</i> ■ <i>No Color Correction</i> 	The downloadable color correction utility files operate only in conjunction with the printer's switches; see page 6-8 for details.

- a. Locate the *LaserWriter Utility* in the folder on your hard disk containing decompressed utility files.
- b. Double-click the *LaserWriter Utility* icon to start the application.
- c. Choose **Download PostScript File** from the **Utilities** menu.
- d. Select the color correction file from the list, then click **Open**.
- e. At the prompt `Save PostScript output as:` you are asked for a file name for saving printer output. Use either the default name given in the edit box or type a new name. Click **Save** to send the file to the printer.

- f. If no output is returned by the printer, the *LaserWriter Utility* displays a dialog box. Click **OK** in the box to continue.
5. Select a print quality mode from the following table, then repeat Steps 3a to 3f for downloading the utility file to the printer.

Macintosh print quality mode utility file

- *Standard Quality*
 - *Enhanced Quality*
 - *High Resolution*
-

6. To print a color sampler chart, do the following:
 - a. Locate the *LaserWriter Utility* in the folder on your hard disk containing decompressed utility files.
 - b. Double-click the *LaserWriter Utility* icon to start the application.
 - c. Choose **Download PostScript File** from the **Utilities** menu.
 - d. Select the color sampler chart file from the list, then click **Open**.
 - e. At the prompt `Save PostScript output as:` you are asked for a file name for saving printer output. Use either the default name given in the edit box or type a new name. Click **Save** to send the file to the printer.
 - f. If no output is returned by the printer, the *LaserWriter Utility* displays a dialog box. Click **OK** in the box to continue.
7. Select colors within an application using the colors on the chart.

8. Print your document using one of the following methods:

If you are printing from a Tektronix driver:

- Print your document using the Tektronix printer driver with the same color correction and print quality options selected in the driver that you used (with downloaded utility files) to print the chart. Any other driver selections can cause the colors to print differently.
- Remember to load the same type of paper and transfer roll you used when printing the chart.

If you are not using a Tektronix driver:

- Print your document with the same downloaded utility files for color correction and print quality that you used to print the chart.
- Remember to load the same type of paper and transfer roll in the printer that you used when printing the chart.

PC and workstation users

1. Copy the color sampler chart files you want to use from the *SAMPLERS* directory on the Windows 3.1 Driver and Printer Utilities diskette onto your computer's hard disk. You may want to place these files in a Utilities directory. Or, you can print these files directly from the diskette.
2. Make sure the printer is loaded with the type of paper and transfer roll you want to use for printing the chart.
3. Select a color correction from the following table:

PC color correction utility file name	Notes
<ul style="list-style-type: none"> ■ <i>DISPLAY.PS</i> ■ <i>VIVDCOLR.PS</i> ■ <i>SIMPRESS.PS</i> ■ <i>NOCORECT.PS</i> 	The downloadable color correction utility files operate only in conjunction with the printer's switches; see page 6-8 for details.

- **PC users:** Use the DOS **COPY** command, described on page 3-19, to send a color correction utility file to the printer. Or, use the **Copy** command in Windows **File Manager**, described on page 3-20, to send a color correction utility file to the printer.
 - **Workstation users:** Send a color correction file to the printer as you would any PostScript file.
4. Select a print quality mode from the following table, then repeat Step 2 for downloading the utility file to the printer.

PC print quality mode utility file
<ul style="list-style-type: none"> ■ <i>STANDARD.PS</i> ■ <i>ENHANCED.PS</i> ■ <i>HIGHRES.PS</i>

5. Print a color sampler chart using one of the following methods:
 - **PC users:** Use the DOS **COPY** command, described on page 3-19, to send a color sampler chart file to the printer.
Or, use the **Copy** command in Windows **File Manager**, described on page 3-20, to send a color sampler chart file to the printer.
 - **Workstation users:** Send a color sampler chart file to the printer as you would any PostScript file.
6. Select colors within an application using the colors on the chart.
7. Print your document using one of the following methods:

If you are printing from a Tektronix driver:

- Print your document using the Tektronix printer driver with the same color correction and print quality options selected in the driver that you used with a downloaded utility file to print the chart. Any other driver selections can cause the colors to print differently.
- Remember to load the same type of paper and transfer roll in the printer that you used when printing the chart.

If you are not using a Tektronix driver:

- Print your document with the same downloaded utility files for color correction and print quality you used to print the chart.
- Remember to load the same type of paper and transfer roll in the printer that you used when printing the chart.

Before printing the PANTONE Color chart

The *PANTONE-Tek Phaser 240 (PANT240.PS)* file prints a PANTONE Color sampler chart (about 46 pages in length). Use the chart to select colors within an application that allows you to specify PANTONE Colors.

Note *Do **not** use any color corrections in a driver or with a downloadable utility file when printing PANTONE Colors from an application. Using any color correction will cause PANTONE Colors to print incorrectly.*

The PANTONE Color sampler chart file contains specific color correction and print quality information required for printing the chart. To match colors from within an application to the sampler chart, you must use the following options:

Color correction	None Select color corrections in a Tektronix Phaser 240 driver or with downloadable utility files; see page 6-5 for more information.
Print quality	High Resolution (You can use Enhanced quality if your printer doesn't have the required memory upgrade for High Resolution, however, colors may not match PANTONE Color standards.) Select print quality modes in a Tektronix Phaser 240 driver or with downloadable utility files; see page 5-8 for more information.
Paper	Thermal-transfer coated paper only.
Transfer Roll	3-Color thermal-wax transfer roll only. (Do not use a ColorCoat transfer roll.)

Printing and using the PANTONE Color chart

Macintosh users

1. Follow the instructions on page 2-13 to decompress the *Phaser 240 Samplers.sea* and the *Phaser 240 Utilities.sea* archive files from the Macintosh Driver and Printer Utilities diskette to your computer's hard disk.
2. Load thermal-transfer coated paper and a thermal-wax transfer roll in the printer. Refer to the *Phaser 240 Color Printer User Manual* for instructions on loading media.
3. Select the appropriate printer in the **Chooser**.
4. To print the chart, following these steps:
 - a. Locate the *LaserWriter Utility* in the folder on your hard disk containing decompressed files. Double-click the *LaserWriter Utility* icon to start the application.
 - b. Select **Download PostScript File** from the **Utilities** menu.
 - c. Select the *PANTONE-Tek Phaser 240* file, and click **Open**.
 - d. At the prompt `Save PostScript output as:` you are asked for a file name for saving printer output. Use the default name given in the edit box or type in a new name. Then click **Save** to send the file to the printer.
 - e. If no output is returned by the printer, the *LaserWriter Utility* displays a dialog box. Click **OK** in the box to continue.
5. Select PANTONE Colors within an application using the colors on the chart.

6. Print your document using one of the following methods:

If you are printing from a Tektronix driver:

- Print your document with the **None** color correction option, and the **High Resolution** print quality mode selected. Any other driver selections will cause the PANTONE Colors to print differently.
- Use thermal-transfer coated paper and a thermal-wax transfer roll in the printer.

If you are not using a Tektronix driver:

- Print your document with the *No Color Correction* color correction utility file, and the *High Resolution* print quality mode utility file, downloaded to the printer. Refer to page 2-14 for instructions on downloading files to the printer.
- Use thermal-transfer coated paper and a thermal-wax transfer roll in the printer.

PC and workstation users

1. Copy the *PANT240.PS* sampler file from *SAMPLERS* directory on the Windows 3.1 Driver and Printer Utilities diskette onto your computer's hard disk. You may want to place this file in a *Utilities* directory. Or, you can print this file directly from the diskette.
2. Load thermal-transfer coated paper and a thermal-wax transfer roll in the printer. Refer to the *Phaser 240 Color Printer User Manual* for instructions on loading media.
3. Print the PANTONE Color chart using one of the following methods:
 - **PC users:** Use the DOS **COPY** command, described on page 3-19, to send the color chart file to the printer.
Or, use the **Copy** command in Windows **File Manager**, described on page 3-20, to send the color chart file to the printer.
 - **Workstation users:** Send the color chart file to the printer as you would any PostScript file.
4. Select PANTONE Colors within an application using the colors on the chart.

5. Print your document using one of the following methods:

If you are printing from a Tektronix driver:

- Print your document with the **None** color correction option, and the **High Resolution** print quality mode selected. Any other driver selections will cause the PANTONE Colors to print differently.
- Use thermal-transfer coated paper and a thermal-wax transfer roll in the printer.

If you are not using a Tektronix driver:

- Print your document with the *NOCORECT.PS* color correction utility file, and the *HIGHRES.PS* print quality mode utility file, downloaded to the printer. Refer to page 3-19 and page 3-20 for instructions on downloading files to the printer.
- Use thermal-transfer coated paper and a thermal-wax transfer roll in the printer.

Using Fonts

This chapter explains how to use fonts and print a font sampler in Macintosh and PC environments.

For general information on fonts, request a document catalog from HAL or EuroHAL, the Tektronix automated fax systems. Refer to page 8-2 for instructions on using these systems.

Printer fonts

In the illustration below, column 1 shows the standard 17 printer fonts, and column 2 shows the optional 22 printer fonts. Refer to the *Phaser 240 Color Printer User Manual* for information on ordering the optional fonts.

Note *If you are not sure of the number of fonts installed in your printer, the printer's startup page lists the number of fonts installed. Refer to page B-2 for instructions on printing a copy of the printer's startup page.*

1	2
Courier	ITC Avant Garde Gothic Book
Courier Bold	<i>ITC Avant Garde Gothic Book Oblique</i>
<i>Courier Oblique</i>	ITC Avant Garde Gothic Demi
Courier Bold Oblique	<i>ITC Avant Garde Gothic Demi Oblique</i>
Helvetica	ITC Bookman Light
Helvetica Bold	<i>ITC Bookman Light Italic</i>
<i>Helvetica Oblique</i>	ITC Bookman Demi
Helvetica Bold Oblique	ITC Bookman Demi Italic
Helvetica Narrow	Helvetica Condensed
Helvetica Narrow Bold	Helvetica Condensed Bold
<i>Helvetica Narrow Oblique</i>	<i>Helvetica Condensed Oblique</i>
Helvetica Narrow Bold Oblique	Helvetica Condensed Bold Oblique
Times Roman	New Century Schoolbook
Times Bold	New Century Schoolbook Bold
<i>Times Italic</i>	<i>New Century Schoolbook Italic</i>
Times Bold Italic	New Century Schoolbook Bold Italic
Symbol (Σ ψ μ β ο λ)	Palatino
	<i>Palatino Italic</i>
	Palatino Bold
	Palatino Bold Italic
	<i>ITC Zapf Chancery</i>
	ITC Zapf Dingbats (☆ * ❄ ❁ ❂ ❃)

Macintosh fonts

Using Macintosh screen fonts

Note *If you already have these fonts installed on your computer, you don't need to install them again.*

The *Phaser Screen Fonts.sea* archive file on the Macintosh Driver and Printer Utilities diskette contains screen fonts for the printer's fonts.

You need to decompress and install the screen fonts on your computer if you want to see the printer's resident typefaces on the Macintosh screen. If you select a font the printer doesn't have, the Macintosh creates a representative font for printing.

Decompressing the fonts

Note Do not decompress fonts directly into the **System Folder**; they must be properly installed after they have been decompressed onto your hard disk.

1. Insert the Macintosh Driver and Printer Utilities diskette into your computer's disk drive.
2. Double-click on the *Phaser ScreenFonts.sea* archive file.
3. At the **Self-Extracting Archive** dialog box, click **Continue**.
4. In the dialog box, select the drive where you want the decompressed fonts saved.
5. At the prompt `Install software as:` you are asked to name the folder where you want the decompressed fonts to reside. Use either the default folder name listed in the edit box or type in the name you want for the folder. Then click **Save**.
6. At the **Installation was successful** dialog box, click **Quit**. The decompressed fonts are saved in the folder you specified.

Installing the decompressed fonts

If you are using System Software 6.0.7:

Use the Font/DA Mover (located on your Apple system software diskettes) to install the fonts you want from the **Phaser Screen Fonts** suitcase.

If you are using System Software 7.0 and later:

Drag the fonts you want from the **Phaser Screen Fonts** suitcase to the *closed System Folder* icon. At the alert message, click **OK**; the fonts are automatically installed in the proper place.

Select the printer font you want to use within an application and see the same font on the screen.

Printing a font sampler from the Macintosh

You can print a sample of the printer's resident fonts by downloading the *Font Sampler* utility file to the printer.

1. Follow the instructions on page 2-13 to decompress the *Phaser 240 Utilities.sea* and *Phaser 240 Samplers.sea* archive files on the Macintosh Driver and Printer Utilities diskette to your computer's hard disk.
2. Select the appropriate printer in the **Chooser**.
3. Locate the *LaserWriter Utility* in the folder on your hard disk containing decompressed utility files.
4. Double-click the *LaserWriter Utility* icon to start the application.
5. Choose **Download PostScript File** from the **Utilities** menu.
6. Select the *Font Sampler* file from the list, then click **Open**.
7. At the prompt `Save PostScript output as:` you are asked for a file name for saving printer output. Use either the default name given in the edit box or type a new name. Click **Save** to send the file to the printer.
8. If no output is returned by the printer, the *LaserWriter Utility* displays a dialog box. Click **OK** in the box to continue.

Downloading fonts to the printer from a Macintosh

The fonts resident in your printer are stored as outlines and are always available for printing. The PostScript interpreter in the printer can also accept and store additional fonts known as downloadable fonts. If you want to print PostScript outline fonts that are not built into the printer, you can transfer or download outline fonts from your computer to the printer. Downloading fonts saves print time if you plan to print several documents or a large document using those fonts.

When you download a font, it is stored in the printer's memory. You can download as many outline fonts as the printer's memory allows.

1. Follow the instructions on page 2-13 to decompress the *Phaser 240 Utilities.sea* archive file on the Macintosh Driver and Printer Utilities diskette to your computer's hard disk.
2. Select the appropriate printer in the **Chooser**.
3. Locate the *LaserWriter Utility* file in the folder on your hard disk containing decompressed utility files.
4. Double-click on the *LaserWriter Utility* icon to start the application.
5. To send fonts to the printer, use the **Download Fonts** command in the **File** menu.

(For instructions on sending PostScript files to the printer, refer to "Using the LaserWriter Utility to download files to the printer" on page 2-14.)

6. Select the font then click **Open**. The font is sent to the printer. The font remains available until the printer is reset or switched off.

PC fonts

Using fonts with Windows

Before printing, you need to make sure the fonts specified in your document are installed in the printer or setup correctly in Windows. If you request a font in an application that is not resident in the printer, or is not correctly installed in Windows, the text is printed in the Courier typeface. Or, to use fonts that are not resident in the printer, do one of the following:

- Use a font downloader supplied with your font package to download the desired font to the printer.
- Edit your *WIN.INI* file so the Tektronix Windows driver automatically downloads the fonts you need as part of a print job. Refer to your Microsoft Windows documentation for details on this procedure.

Some font packages automatically update the PostScript port entries in your *WIN.INI* file when you reinstall the fonts. Refer to the font package's documentation for instructions.

For more information on using fonts with Windows, request a document catalog from HAL or EuroHAL, the Tektronix automated fax systems. Refer to page 8-2 for instructions on using these systems.

Printing a font sampler from a PC

You can print a sample of the printer's resident fonts by downloading the *FONTS.PS* utility file to the printer.

1. Locate the *FONTS.PS* file in the *SAMPLERS* directory on the Windows 3.1 Driver and Printer Utilities diskette.
2. Copy the file to your hard disk, or use the file from the diskette.
3. Use one of the following methods to send the file to the printer:
 - **PC users:** Use the DOS **COPY** command, described on page 3-19, to send the *FONTS.PS* file to the printer. Or, use the **Copy** command in Windows **File Manager**, described on page 3-20, to send the *FONTS.PS* file to the printer.
 - **Workstation users:** Send the *FONTS.PS* file to the printer as you would any PostScript file.

Downloading fonts to the printer from a PC

The fonts resident in your printer are stored as outlines and are always available for printing. The PostScript interpreter in the printer can also accept and store additional fonts known as downloadable fonts. If you want to print PostScript outline fonts that are not built into the printer, you can transfer or download outline fonts from your computer to the printer. Downloading fonts saves print time if you plan to print several documents or a large document using those fonts.

When you download a font, it is stored in the printer's memory. You can download as many outline fonts as the printer's memory allows.

A font downloader is an interactive program that lets you transfer Adobe fonts and other PostScript files to the printer. Check your font package for a downloader application. Or, check the Tektronix Bulletin Board Service (BBS) for a PC font downloader; refer to page 8-1 for instructions.

Troubleshooting

Getting help

Using the Tektronix Bulletin Board Service

The Tektronix Bulletin Board Service (BBS) is available for direct downloading of the latest versions of printer drivers, utilities, and files. If you have a Macintosh or PC, communication software, and modem, you can call the system and use the menus to locate and download the files you want.

To access the BBS 24 hours a day, 7 days a week, call (503) 685-4504.

For a detailed instruction guide on system requirements, terminal settings, protocol, modem, how to connect to our BBS, and how to download files, request a document catalog from HAL or EuroHAL, the Tektronix automated fax systems. Refer to page 8-2 for instructions on using these systems.

Reaching the Customer Support staff

If your problem is still not resolved after trying the suggestions in this chapter, call the Tektronix Customer Support Hotline in the United States Monday through Friday, from 6 AM to 5 PM PST at 1-800-835-6100. Outside the U.S., contact your reseller or local Tektronix office.

Also, refer to the HAL catalog for articles on using the printer, specific applications, and computing environments; see page 8-2 for instructions on using HAL and EuroHAL.

Using the automated fax systems

As an alternative to using the Customer Support Hotline, and to provide up-to-date information quickly, Tektronix has set up HAL and EuroHAL, two interactive, automated fax systems. These automated fax systems provide Macintosh, PC, and workstation users with the latest technical hints and tips (like color matching), solutions to common technical problems, and application notes (like CorelDRAW! and QuarkXPress).

You may call HAL or EuroHAL from anywhere in the world. The fax systems are available 24 hours a day, seven days a week.

Use HAL in the U.S.A. and Canada

If you have a fax machine and a touch-tone voice telephone, you can order a HAL catalog listing all of the information offered by HAL.

Note *Before ordering documents from HAL, order a catalog listing the numbers of available documents. You may want to replace your catalog periodically, since the system is often updated.*

1. Before you call, write down the area code and telephone number for your fax machine. HAL will ask you to key this number through the keypad on your voice telephone.
If you are calling from outside the United States or Canada, you'll need to know the international access code to reach your country from the United States. Without a complete fax number, HAL cannot call your fax machine.
2. Call **(503) 682-7450** (direct) or, in the U.S. and Canada, call **1-800-835-6100** (at the prompt, choose the option for technical documentation via fax).
Call only from a touch-tone voice telephone.
3. Follow through the voice-prompted (English) menu.
4. Order individual documents by entering the desired document's number as listed in the HAL catalog. Enter the number by using your telephone's keypad.
5. You can order up to three documents per call.
6. The HAL catalog or documents you request are faxed to you in a matter of minutes.

Use EuroHAL in Europe

EuroHAL includes many documents, some in English and some in other European languages. If a local version of the document you want is available, EuroHAL will send it in your language. Otherwise, it will send English documents.

If you have a tone-dial telephone and a fax machine, then you can use EuroHAL. If your telephone has star (*) and hash mark (#) keys then it can probably use tones; ask your local telephone supplier if you are not sure.

If your telephone does not have these keys or has a dial, you will need to buy a *tone dialer* from your local telephone or electronics shop. This small box is held to the phone and will send the standard tones that you need to talk to EuroHAL.

1. To use EuroHAL, call one of the numbers listed in the following table.

Country	Number
Austria	00 44 1628 478 347
Belgium	00 44 1628 478 347
Denmark	00 44 1628 478 347
Finland	990 44 1628 478 347
France	05 90 81 86
Germany	0130 819 220
Holland	00 44 1628 478 347
Italy	00 44 1628 478 347
Norway	095 44 1628 478 347
Spain	07 44 1628 478 347
Sweden	0 09 44 1628 478 347
Switzerland	00 44 1628 478 347
UK	01628 478 347
Other countries	+44 1628 478 347 (where + is your country's International Access Code)

2. EuroHAL answers and asks which language you want to use.

For English	Press 1
For French	Press 2
For German	Press 3

3. The first time you use EuroHAL, you should order a catalog. This lists all the available documents, and is constantly updated.

4. EuroHAL asks you for your fax machine number. If you are calling from outside the UK, add your country code first, as shown in the following table.

Country	Country code	Your area code and fax number	Press # when finished
Austria	00 43	area code fax number	#
Belgium	00 32	area code fax number	#
Denmark	00 45	area code fax number	#
Finland	00 358	area code fax number	#
France	00 33	area code fax number	#
Germany	00 49	area code fax number	#
Holland	00 31	area code fax number	#
Italy	00 39	area code fax number	#
Norway	00 47	area code fax number	#
Spain	00 34	area code fax number	#
Sweden	00 46	area code fax number	#
Switzerland	00 41	area code fax number	#
UK		just enter your fax number	#
Other countries	00 xx	area code number	#

Downloading Tektronix files from the Internet

If you don't have the means of transferring files from the Windows 3.1 Driver and Printer Utilities diskette for PC/DOS, you can request files from the Tektronix Color Printer Information Server, an automatic file serving program that responds to requests for files.

If you can exchange electronic mail with other Internet sites, you can access the Tektronix Color Printer Information Server. From this server you can retrieve driver and utility files and color printer information.

In the following mail requests, substitute the library of your choice for ***library-name***, and the file of your choice for ***filename***.

Send your requests for files to the following electronic mail address:

`color_printer_info@TEKTRONIX.TEK.COM`

Electronic mail requests

To	Type this command
Receive the list of information available on the server	<code>send index</code> (type this at the Subject prompt)
Examine the full index for any library	<code>send index from <i>library-name</i></code>
Request a file from a library	<code>send <i>filename</i> from <i>library-name</i></code>
Determine a file's size	<code>send list of <i>filename</i> from <i>library-name</i></code>

Other electronic addresses and telephone numbers

Customer services, technical support, ordering and service	1-800-835-6100
HAL fax library	<ul style="list-style-type: none"> ■ 1-800-835-6100 ■ (503) 682-7450
Bulletin Board Service (BBS)	(503) 685-4504
Internet	<ul style="list-style-type: none"> ■ Worldwide Web: http://www.tek.com/CPID/ ■ Automatic File Server: color_printer_info@tek.com ■ Technical Support: support@ColorPrinters.tek.com
America On-Line	Keyword: Tektronix
eWorld	Shortcut: Tektronix
CompuServe	Go Tektronix

Opening the READ ME files on the Macintosh diskette

The Tektronix Macintosh Driver and Printer Utilities diskette contains a *READ ME* file providing information that arrived too late to be included in this manual. This *READ ME* file was written in the *TeachText* program. You must have a copy of *TeachText* (or *SimpleText* for system 7.1 and later) installed on your hard disk to read this file. If you don't have a copy already installed, copy *TeachText* (or *SimpleText*) from the same Apple system software diskettes you last used to upgrade your computer.

Solving PostScript printing problems

PostScript printing errors

Note *For information on specific applications, request a document catalog from HAL or EuroHAL, the Tektronix automated fax systems. Refer to page 8-2 for instructions on using these systems.*

If you get a PostScript error when printing from Aldus PageMaker, Aldus FreeHand, QuarkXPress, or Canvas, you may be using an older or incorrect version of the printer description file. Refer to “Printing from an application” on page 2-19 (Macintosh), or page 3-25 (PC), for instructions on using printer description files.

When using printer description files, it is important to match the application’s version number to the printer’s firmware version number. You can check the printer’s firmware version number by printing a copy of the printer’s startup page. Refer to page B-2 for instructions on printing the startup page. If you have upgraded your printer’s firmware version, you may need a newer printer description file.

You should always use the most current printer description file. To determine the **date** of the file you are using, do the following:

1. Macintosh users:

Select (highlight) a printer description file and choose **Get Info** from the **File** menu. Make a note of the version date.

PC/Windows users:

Check a printer description file’s creation date in the **File Manager**. Make a note of the version date.

- 2.** Check the Tektronix Bulletin Board Service (BBS) to see if the printer description files you have are the most recent. Refer to page 8-1 for instructions on using the BBS.

Random PostScript errors

If you are using AppleTalk Network Software below version 58.x, you may experience a problem with random PostScript errors when printing. If this is the case, you should upgrade the AppleTalk Network Software on your Macintosh computer.

The printing problem is due to a timing conflict between the older AppleTalk software and the printer. The PostScript errors can be any type of error or offending command, and may occur in any of the following situations:

- May occur more often over LocalTalk than EtherTalk.
- Sending the same file more than once may cause different errors or offending commands each time, or the file may print without an error.
- Files from some applications may print, while files from other applications may not.
- Documents saved to PostScript files and sent to the printer with a downloading utility may generate errors.

To upgrade your software

1. Insert the diskette labeled “AppleTalk Installer for the Macintosh” into your computer’s disk drive. This diskette was shipped with your printer.
2. Double-click on the **Installer** icon.
3. Click **OK** in the introduction screen.
4. Click **Install** in the **Easy Install** window to install the recommended software. (Or, click **Customize** to select individual items.)
5. After successful installation, click **Restart** to restart your computer.

Using a PostScript error handler

The error handling utility is useful for diagnosing problems when a job doesn't print. This utility installs a PostScript error-handling function in the printer to help determine the cause of some PostScript printing problems. PostScript errors are printed on a page with other status information when an error occurs. This utility can be useful to programmers for debugging PostScript code.

To turn on the error handler, follow the instructions below. To turn off the error handler, follow the instructions on page 8-23 to reset the printer.

Use the utility files for your computer type.

Macintosh file name	PC file name
<i>LaserWriter Utility and Tek Error Handler</i>	<i>TEKEHAND.PS</i>

Macintosh users

Note *If you are using System Software 7.5 and QuickDraw GX, you can also download this printer utility from the Tektronix Phaser 240 GX printer driver; refer to page A-11 for instructions.*

1. Follow the instructions on page 2-13 to decompress the *Phaser 240 Utilities.sea* archive file on the Macintosh Driver and Printer Utilities diskette to your computer's hard disk.
2. Select the appropriate printer in the **Chooser**.
3. Locate the *LaserWriter Utility* in the folder on your hard disk containing decompressed utility files.
4. Double-click the *LaserWriter Utility* icon to start the application.
5. Choose **Download PostScript File** from the **Utilities** menu.
6. Select the *Tek Error Handler* file from the list, then click **Open**.

7. At the prompt `Save PostScript output as:` you are asked for a file name for saving printer output. Use either the default name given in the edit box or type a new name. Click **Save** to send the file to the printer.
8. If no output is returned by the printer, the *LaserWriter Utility* displays a dialog box. Click **OK** in the box to continue.

PC and workstation users

1. Locate the *TEKEHAND.PS* file in the *PHSR240* directory on the Windows 3.1 Driver and Printer Utilities diskette.
2. Copy the file to your hard disk, or use it from the diskette.
3. Use one of the following methods to send the file to the printer:
 - **PC users:** Use the DOS **COPY** command, described on page 3-19, to send the *TEKEHAND.PS* file to the printer.
Or, use the **Copy** command in Windows **File Manager**, described on page 3-20, to send the *TEKEHAND.PS* file to the printer.
 - **Workstation users:** Send the *TEKEHAND.PS* file to the printer as you would any PostScript file.

Improving print speed

Note *There are different ways to improve print speed, such as by upgrading to EtherTalk on a Macintosh, to Novell on a PC, or to TCP/IP on a workstation. For more information, request a document catalog from HAL or EuroHAL, the Tektronix automated fax systems. Refer to page 8-2 for instructions on using these systems.*

If you tried to print a document with bitmapped images, but are dissatisfied with the speed of the output, here are some suggestions.

All users

- When you use any color correction option (other than **None**), your printer can take longer to process bitmapped images. Select color corrections from the Tektronix drivers or with downloadable utility files; see page 6-5 for instructions.
- The **Standard** option prints faster than the **Enhanced** and **High Resolution** options. Select these print quality modes from the Tektronix drivers or with downloadable utility files; see page 5-8 for instructions.
- The printer is shipped with 5 Mbytes of memory. Adding more memory to your printer increases the data throughput from your computer to the printer. See the *Phaser 240 Color Printer User Manual* for details and ordering information.

Windows users

- Turn off the **Print Manager**; printing via the **Print Manager** is slower, but turning it off ties up the PC longer.
- Select the Tektronix Phaser 240 printer in the **Printers** dialog box.
- Make sure the **Use PostScript Level 2 Features** check box in the **Advanced Options** dialog box is turned on.
- From your application, choose the **Tektronix Phaser 240** as your printer.
- Try printing the document again.

UNIX workstation users

Workstation users can use the Phaser Print software to increase printer performance when printing bitmapped images. Refer to page 4-2 for details on Phaser Print.

If your file doesn't print

If you've configured the Tektronix driver for your printer but your printer isn't printing, try the following suggestions. If these suggestions fail to solve the problem, copy the Tektronix PostScript Level 2 error handler utility to your printer to determine what is wrong. Refer to page 8-9 for information on using the error handler.

General things to check for

Macintosh users

- Open the **Chooser** and select the **Tektronix Phaser 240** driver and the printer you want to use.
 - If the driver isn't installed, refer to page 2-2 for instructions.
 - If **Background Printing** is turned **on**, turn it **off**.
 - Close the **Chooser** and try printing again.
- If you are having trouble printing from the Finder in System 7.1, for example if the Phaser 240 driver dialog boxes are not opening, it may be because the Finder doesn't have enough allocated memory. Reinstall the Tektronix driver to automatically allocate enough memory for printing from the Finder.

Windows users

- Make sure your printer is connected to the port you selected in the **Printers/Connect** dialog box.
- Try resetting the **Transmission Retry** timeout option in the **Printers/Connect** dialog box to **850** seconds.
- Check to make sure you have configured the communications ports and the Handshake option correctly. Refer to page B-4 to print a configuration page for helpful information.
- Check the **Options** dialog box to make sure **Printer**, not **Encapsulated PostScript File**, is selected in the **Print To** box.

- The following error message appears on your computer screen:
Windows Header has not been downloaded to the printer.
Open the **Options** dialog box and turn on the **Send Header with Each Job** check box. Refer to page 3-10 for details.

If you are using PC/NFS

If you have PC/NFS software installed on your computer, you need to make the following selection in the **Network Options** dialog box:

1. From the **Main** window, double-click the **Print Manager** icon.
2. From the **Options** menu in the **Print Manager**, select **Network Settings**.
3. In the **Network Options** dialog box, uncheck the **Print Net Jobs Direct** box.
4. Click **OK**.

If you can't print from Windows to an LPT port

If your printer is connected through an LPT (parallel) port and your document doesn't print, try the following:

1. Double-click the **Printers** icon in the **Control Panel**.
2. In the **Printers** dialog box, choose your printer from the list of installed printers.
3. Click the **Connect** button; the **Connect** dialog box appears.
4. Change your port connection from **LPTx** to **LPTx.DOS** (where x is 1, 2, or 3).
5. Click **OK**.

Check the printer's language mode

If you are using a PC or workstation and your file doesn't print, the language on the printer's port you are using may have been changed.

1. Print a copy of the printer's configuration page to see the language mode on each port. Refer to page B-4 for instructions on printing a configuration page.

(If the configuration page doesn't print, try this procedure:

Place Switches 2, 3, and 4, inside the printer's rear panel door, in the *down* position. Then put Switch 4 *up*. After the configuration page prints, place Switch 4 down.)

2. If the printer port you are using has the wrong language set for the type of application you are using, send one of the following utility files to the printer:
 - To print PostScript files, use the *PSCRIPT.PS* file to set up a port to receive PostScript; see page C-5 for details.
 - To print HP-GL files, use the *HPGL.PS* file to set up a port to receive HP-GL; see page C-5 for details.
 - To print PostScript, HP-GL, or PCL5 files, use the *AIS.PS* file to set up a port for automatic language selection; see page C-6 for details.

Fixing timeout problems in Windows

Try one of the following procedures to correct Windows timeout problems. If the Windows procedure doesn't work for you, try the DOS procedure.

From Windows

1. Open the **Control Panel** from the **Main** menu.
2. Double-click the **Printers** icon to open the **Printers** dialog box.
3. Click the **Connect** button to open the **Connect** dialog box.
4. Increase the **Transmission Retry** to **850** seconds by typing in the new number.
5. Click **OK**.

From DOS

Note *To use this procedure, the printer must be connected directly to your computer, not on a network.*

1. At the DOS prompt, issue the DOS **MODE** command by typing the following:

```
MODE LPT1: , , P
```
2. Start Windows.
3. Open the **Control Panel** from the **Main** menu.
4. Double-click the **Printers** icon to open the **Printers** dialog box.
5. Click the **Connect** button to open the **Connect** dialog box.
6. Change the port selection from **LPT1** to either **LPT1.DOS** or **LPT1.OS2**, depending on the options you see in the dialog box.
7. Click **OK**.

Printed colors are not what you expected

In general

- Select another **Color Correction** option in the driver and print your image again. Refer to page 6-5 for more information.
- If you are not using a Tektronix driver and are sharing the printer with other users on a network, another user may have changed the printer's color correction setting. Refer to page 8-21 for more information.
- If you use the driver's **Use Printer's Settings** option and printed colors are not what you expected, check to see if a color correction utility file has been downloaded to the printer. These utility files change the printer's color correction setting. Refer to page 8-21 for details on how these settings affect prints made from the driver.

Printing PANTONE Colors

If Phaser 240-specific PANTONE Colors are not printing as expected, make sure you are printing without any color corrections, and with the appropriate print quality mode, paper, and transfer roll. Refer to “Before printing the PANTONE Color chart” on page 6-22 for more information.

If you have questions about PANTONE Color Matching, refer to the HAL article on PANTONE. Refer to page 8-2 for instructions on using HAL and EuroHAL.

Blue colors look too purple

If printed blue colors look too purple, print your document with the Vivid Color color correction. Refer to “Using color corrections” on page 6-4 for instructions and more information.

Colors are printing incorrectly

Tektronix halftone screens are designed for Tektronix printers, and improve print quality over application-set halftone screens. The *Setscreen Patch* utility file redefines the *setscreen*, *setcolorscreen* and *sethalftone* PostScript operators. When downloaded to the printer, this file prevents applications from overriding the Tektronix proprietary halftone screens.

Use the utility files for your computer type.

Macintosh file name	PC file name
<i>LaserWriter Utility</i> and <i>Setscreen Patch</i>	<i>SETSCRN.PS</i>

Macintosh users

1. Follow the instructions on page 2-13 to decompress the *Phaser 240 Utilities.sea* archive file on the Macintosh Driver and Printer Utilities diskette to your computer's hard disk.
2. Select the appropriate printer in the **Chooser**.
3. Locate the *LaserWriter Utility* in the folder on your hard disk containing decompressed utility files.
4. Double-click the *LaserWriter Utility* icon to start the application.
5. Choose **Download PostScript File** from the **Utilities** menu.
6. Select the *Setscreen Patch* file from the list, then click **Open**.
7. At the prompt `Save PostScript output as:` you are asked for a file name for saving printer output. Use either the default name given in the edit box or type a new name. Click **Save** to send the file to the printer.
8. If no output is returned by the printer, the *LaserWriter Utility* displays a dialog box. Click **OK** in the box to continue.

PC and workstation users

Use one of the following methods to send the file to the printer:

- **PC users:** Use the DOS **COPY** command, described on page 3-19, to send the *SETSCRN.PS* file to the printer.
Or, use the **Copy** command in Windows **File Manager**, described on page 3-20, to send the *SETSCRN.PS* file to the printer.
- **Workstation users:** Send the *SETSCRN.PS* file to the printer as you would any PostScript file.

Selecting page sizes in Windows applications

In some Windows applications, you can select printer page sizes in a **Print Setup** dialog box accessed from the **File** menu. If you use a **Print Setup** dialog box to select the Phaser 240 from your application, some page sizes may not be visible in the list.

If the Phaser 240 page size you want to use is not visible in the list, do the following:

1. From the **Main** window, open the **Control Panel** and double-click the **Printers** icon.
2. In the **Printers** dialog box, select the **Phaser 240** in the list of printers.
3. Click the **Setup** button.
4. In the **Setup** dialog box, select the page size you want and click **OK**.
5. Return to your application. If you open the **Print Setup** dialog box again from within your application, the page size selection may be blank. The page size you just selected in the driver is still selected, it is just not visible in the list.
6. Print as usual.

If you open the **Print Setup** dialog box from within an application, and the page size selection is blank, the blank represents the page size last selected from the printer driver through the **Control Panel**. You can leave the page size selection blank and print as usual, or you can select a page size from the list.

Sharing the printer on a network

Driver and utility file interactions

If your Phaser 240 printer is shared by other users on a network, using the downloadable utility files to change the printer's color correction setting, can affect prints made by other users.

If the colors on your prints are not what you expected, ask your system administrator whether a color correction utility file has been downloaded to the printer. You can also print a configuration page (or startup page) to see the printer's current color correction setting; see page B-4 for instructions.

Note *Refer to page 6-8 for more information on using color correction utility files.*

- When you print from a Tektronix driver with any TekColor color correction option (*except Use Printer Setting*), the driver selection overrides the following selections *for prints made from the driver*:
 - A color correction utility file, if one has been downloaded to the printer.
 - The position of the printer's switches (located inside the rear panel door). Switch 3 *down* turns off all color corrections. Switch 3 *up* is **Vivid Color**, the factory default color correction, *if no utility file has been downloaded*.
- When you print from a Tektronix driver with the **Use Printer Setting** option, your images are printed with the color correction setting currently in the printer's memory:
 - A color correction utility file, if one has been downloaded to the printer.
 - The position of the printer's switches (located inside the rear panel door). Switch 3 *down* turns off all color corrections. Switch 3 *up* is **Vivid Color**, the factory default color correction, *if no utility file has been downloaded*.

- When you print from a non-Tektronix driver, your images are printed with one of the following selections:
 - A color correction utility file, if one has been downloaded to the printer.
 - The position of the printer's switches (located inside the rear panel door). Switch 3 *down* turns off all color corrections. Switch 3 *up* is **Vivid Color**, the factory default color correction, *if no utility file has been downloaded*.

LaserWriter Utility does not work

The *LaserWriter Utility* cannot be used if the printer is connected to a print server. See your system administrator to temporarily remove the printer from the print server to download any of the PostScript utility files.

Resetting the printer

The *Reset Printer (RESET.PS)* file resets the printer to its power-on conditions (*not* its factory default conditions), without turning the printer's power switch off and on. The power-on conditions include any custom changes made to the printer that are stored in the printer's NVRAM, or changes that are persistent across printer power cycles. For example, if you used a downloadable utility file to change the printer's name, or set a color correction, these are power-on conditions that are not altered by resetting the printer. Resetting the printer erases changes that are not persistent across printer power cycles, such as the Tektronix error handler utility and downloaded fonts.

This file restarts the printer as soon as all the jobs in its queue are finished. The printer remains unavailable while it initializes.

Use the utility files for your computer type.

Macintosh file name	PC file name
<i>Reset Printer and LaserWriter Utility</i>	<i>RESET.PS</i>

Macintosh users

Note *Do not use the **Restart Printer** command in the LaserWriter Utility's **Utilities** menu. Follow this procedure to reset the printer using the LaserWriter Utility to download the Reset Printer utility file.*

If you are using System Software 7.5 and QuickDraw GX, you can also download this printer utility from the Tektronix Phaser 240 GX printer driver; refer to page A-11 for instructions.

1. Follow the instructions on page 2-13 to decompress the *Phaser 240 Utilities.sea* archive file on the Macintosh Driver and Printer Utilities diskette to your computer's hard disk.
2. Select the appropriate printer in the **Chooser**.

3. Locate the *LaserWriter Utility* in the folder on your hard disk containing decompressed utility files.
4. Double-click the *LaserWriter Utility* icon to start the application.
5. Choose **Download PostScript File** from the **Utilities** menu.
6. Select the *Reset Printer* file in the list then click **Open**.

Note *The process of resetting the printer takes a few minutes to complete. You will receive a message on your screen indicating the connection has been interrupted during the reset. The connection is re-established after the reset, so you can ignore this message; click the **Continue** button.*

7. At the prompt `Save PostScript output as:` you are asked for a file name for saving printer output. Use either the default name given in the edit box or type in a new name. Click **Save** to send the file to the printer.
8. If no output is returned by the printer, the *LaserWriter Utility* displays a dialog box. Click **OK** in the box to continue.

PC and workstation users

1. Locate the *RESET.PS* file in the *PHSR240* directory on the Windows 3.1 Driver and Printer Utilities diskette.
2. Copy the file to your hard disk, or use the file from the diskette.
3. Use one of the following methods to send the file to the printer:
 - **PC users:** Use the DOS **COPY** command, described on page 3-19, to send the *RESET.PS* file to the printer.
Or, use the **Copy** command in Windows **File Manager**, described on page 3-20, to send the *RESET.PS* file to the printer.
 - **Workstation users:** Send the *RESET.PS* file to the printer as you would any PostScript file.

If you have problems using the paper trays

The Phaser 240 comes standard with a paper tray for use with perforated paper. An optional kit enabling you to print on plain paper, and a separate lower tray assembly are also available. For Product Information in the U.S. and Canada, call 1-800-835-6100. Outside the U.S. and Canada, contact your reseller or local Tektronix office.

If you have problems with the paper trays, you may find it helpful to understand how paper tray switching works. The following list outlines paper tray behavior and offers suggestions for you to try.

- Make sure your media selection matches your tray selection. For example, if you select Letter-size paper, you must also have a Letter-size tray in the printer in either the upper or lower positions.
- The lower tray is the default. If you use a driver that doesn't allow you to select the upper or lower tray, or if you do not tell the printer which tray to pick media from (through the driver or with a utility file), it picks from the lower tray. When this tray runs out of media, the front panel media indicator lights up and printing stops until the tray is filled.
- If you select the upper tray or the lower tray from a Tektronix driver or with a utility file, that selection is locked onto that tray.
 - If a job doesn't print, make sure the selected tray contains media.
 - If the selected tray runs out of media, the front panel media indicator lights up and printing stops until the tray is filled or until the other tray is selected through a driver or with a utility file.

- If you want the printer to automatically take media from the second tray when the first tray is empty, select **Auto Select** in a Tektronix driver, or send the *Use Any Tray (ANYTRAY.PS)* file to the printer, *and* make sure both trays contain the same media type and size. If the trays contain two different types or sizes of media, the printer will not automatically switch from one tray to the other.
- Refer to the *Phaser 240 Color Printer User Manual* for more information on paper trays.

A

Using the Phaser 240 GX Driver

If you are using a Macintosh with QuickDraw GX and System Software 7.5, use the Phaser 240 GX driver to print to your Phaser 240 printer.

- The Phaser 240 GX driver works with QuickDraw GX applications and with non-QuickDraw GX applications.
- QuickDraw GX doesn't work with non-QuickDraw GX printer drivers. If you want to print from non-QuickDraw GX applications with the Tektronix Phaser 240 driver (based on the LaserWriter 7.1.2. printer driver) described in Chapter 2, you must disable QuickDraw GX; see page A-21 for instructions.

System requirements

The Tektronix Phaser 240 GX printer driver requires the following hardware and software:

- An Apple Macintosh II computer, or later
- At least 8 Mbytes of RAM
- QuickDraw GX and System Software version 7.5

Installing the Phaser 240 GX printer driver

1. Make sure your Macintosh is turned on with QuickDraw GX and system software version 7.5 installed.
2. Insert the Macintosh Driver and Printer Utilities diskette into the disk drive.
3. When the diskette appears on the desktop, it should be open showing the icons inside.
4. Drag the **Phaser 240 GX** driver icon from the diskette to the **closed System Folder** icon on your Macintosh hard disk. At the alert message, click **OK** to automatically install the driver in the *Extensions* folder.
5. Store the printer diskette in a safe place.

Note *Before you can print, you need to create a desktop printer; go on to page A-3 for instructions.*

Creating a desktop printer

QuickDraw GX requires you to create desktop printers for printing. Depending on the type of application you are using, printing is as easy as dragging a document onto a desktop printer icon.

1. Select **Chooser** from the **Apple** menu.

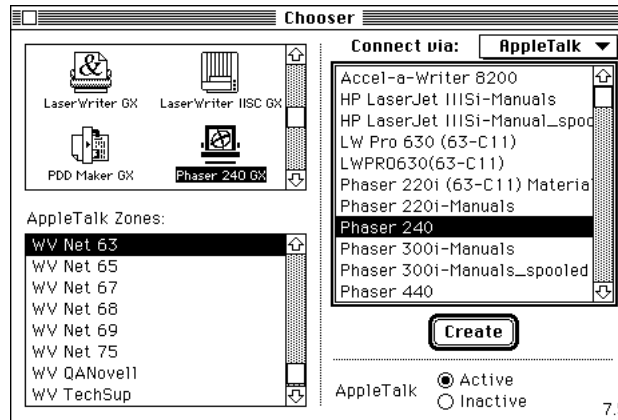

2. Click the **Phaser 240 GX** printer driver icon on the left side of the **Chooser**. A list appears with the printers available on your network. (If the printer driver icon does not appear, **Restart** your Macintosh, and repeat the printer driver installation procedure; also check the cable connections on your computer and printer.)
3. In the **Connect via** field's pop-up menu, select your printer's communication method:
 - The **AppleTalk** option is the standard network connection.
 - The **Servers** option is used to select a shared desktop printer; see page A-14 for details.
4. Click on your Phaser 240 in the list of printers on the right side of the **Chooser**.

5. If you want to rename the printer listed in the **Chooser**, do so *before* creating any desktop printers. If you rename the printer in the **Chooser**, any desktop printers referring to that printer will not work, and must be removed to the Trash and recreated.

See page 2-17 for instructions on using the *LaserWriter Utility* to rename the printer.

6. Click the **Create** button to create a desktop printer. An icon of the printer appears on the desktop with the same name as the printer selected in the Chooser.



Phaser 240

7. Close the **Chooser** by clicking its close box.

Using a desktop printer

Setting up unique desktop printers

You can create more than one desktop printer of the same physical printer. Each desktop printer can be set up with different print modes or options and given a descriptive name. This feature makes it easy to print to a specific printer with the options you want already selected. In the illustration below, a desktop printer has been created of a Phaser 240 with the Vivid Color color correction and the Paper media type selections.



Phaser 240-Vivid Color-Paper

1. Create a desktop printer according to instructions on page A-3.
2. Select (highlight) a desktop printer icon.
The **Printing** menu appears in the menu bar at the top of the Macintosh screen.



3. Use the **Printer Driver Defaults** command in the **Printing** menu to select options for desktop printers; see page A-10 for details.
4. To rename the desktop printer, highlight the icon on the desktop and type a new name. Renaming a desktop printer has no effect on the printer name in the Chooser.

Printing with a desktop printer

If you are using GX-aware applications

- Select any desktop printer in the **Print** dialog box.
- Drag a document onto a desktop printer icon. The application corresponding to the document opens, prints the document, and then quits.

If you are using non-GX-aware applications

- Print to the *default* desktop printer with the **Print** command from the **File** menu.
- Drag a document onto a desktop printer icon. The application corresponding to the document opens, the **Print** dialog box and waits for you to click **Print**. After printing the document, the application quits.

Using the Printing menu

Most of the commands in the **Printing** menu are standard QuickDraw GX driver commands, and are documented by Apple (see the *Macintosh Guide* on-line document for details). The last group of commands in this menu are printer-specific.



Control printing

Use the **Start Print Queue** and **Stop Print Queue** commands in the **Printing** menu to control the print queues on individual desktop printers.

1. Select (highlight) a desktop printer icon.
2. From the **Printing** menu, select the appropriate command.

Designating a default desktop printer

1. Select (highlight) a desktop printer icon.



Phaser 240

2. From the **Printing** menu, select **Set Default Printer**.
A check-mark appears next to the command, and a bold outline appears around the desktop printer icon.



Phaser 240

Controlling input trays

If you select the **Input Trays** command in the **Printing** menu, the following message appears:

Please use the **Printer Driver Defaults** command to specify media options for this printer.

Click **OK** to continue, then use the **Printer Driver Defaults** command in the **Printing** menu to select media trays.

Using printing extensions

Use the **Extension Setup** command in the **Printing** menu to specify which third-party printing extensions you want enabled for the currently selected desktop printer. For example, **Print Time** and **Paper Match** are part of the QuickDraw GX software and are always available. By default, all printing extensions are enabled.

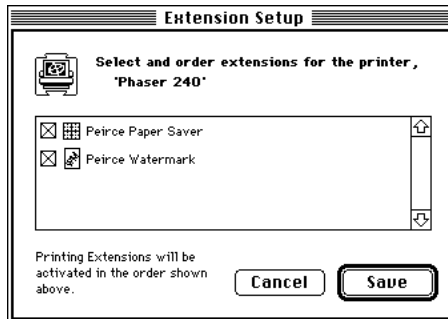

1. Select (highlight) a desktop printer icon.
2. Select **Extension Setup** from the **Printing** menu.
3. Make selections as desired.

Selecting printing options

Use the **Printer Driver Defaults** command in the **Printing** menu to set default options for the selected desktop printer. This dialog box includes the color corrections, tray selections, and print quality mode options.

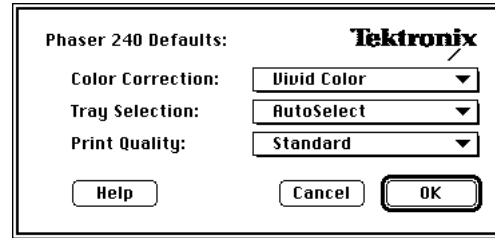

Note *The printer defaults dialog box is also available through the **Print** command in the **File** menu for QuickDraw GX-aware applications.*

Phaser 240 Defaults	Options	Where to find details
Color Correction	<ul style="list-style-type: none"> ■ None ■ Vivid Color ■ Simulate Display ■ Simulate Press ■ Monochrome ■ Use Printer Setting 	See page 6-5
Tray Selection	<ul style="list-style-type: none"> ■ Upper Tray ■ Lower Tray ■ AutoSelect 	See page 5-6
Print Quality	<ul style="list-style-type: none"> ■ Standard ■ Enhanced ■ High Resolution 	See page 5-8

Downloading printer utilities

Use the **Printer Utilities** command in the **Printing** menu to download printer utility files to the selected desktop printer. This command cannot be used on a shared printer, except by the Macintosh hosting the shared printer; the command is not visible in the menu.

1. Select (highlight) a desktop printer icon.
2. Select **Printer Utilities** from the **Printing** menu.
3. In the **Utility** pop-up menu, select the utility you want downloaded to the printer, then click **OK**.

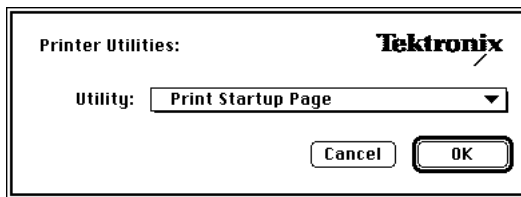

4. If you see an alert message, click **OK** or **Cancel**.

The utilities in the following table can be downloaded to the printer with the **Printer Utilities** command from the **Printing** menu.

Utilities	Where to find details
■ Print Startup Page	See page B-2
■ Print Configuration Page	See page B-4
■ Print CMYK Sampler	See page 6-14
■ Print HSB Sampler	
■ Print RGB Sampler	
■ Print Fonts Sampler	See page 7-5
■ Disable Startup Page	See page B-2
■ Enable Startup Page	
■ Download Tek Error Handler	See page 8-9
■ Download Setscreen Patch	See page 8-18
■ Reset Printer	See page 8-23
■ Use Lower Tray	See page 5-6
■ Use Upper Tray	
■ Use Any Tray	
■ Use Standard Quality	See page 5-8
■ Use Enhanced Quality	
■ Use High Resolution Quality	
■ Enable No Color Corrections	See page 6-5
■ Enable Vivid Color	
■ Enable Simulate Display	
■ Enable Simulate Press	
■ Enable Monochrome	
■ Enable Raw RGB Colors	
■ Enable Raw CMYK Colors	

Download PostScript files

Use the **Send PostScript File** command in the **Printing** menu to download PostScript files to the selected desktop printer. This command cannot be used on a shared printer, except by the Macintosh hosting the shared printer; the command is not visible in the menu.

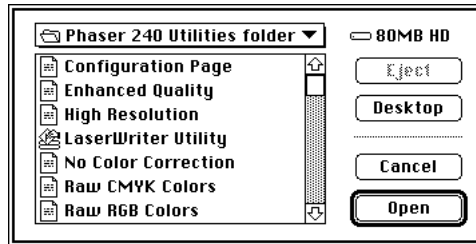

1. Select (highlight) a desktop printer icon.
2. Select **Send PostScript File** from the **Printing** menu.
3. Select the PostScript file you want to download.
4. Click **Open** to send the file to the printer.

About shared printers

You can share a desktop printer in the same way you share files, folders, or volumes, with the **Sharing** command in the **File** menu. Both the host and client computers must have a copy of the same printer driver.

Setting up a shared printer

1. Create a desktop printer according to the instructions on page A-3.
2. Highlight the desktop printer icon you want to share.



3. Select **Sharing** from the **File** menu.
4. Click the check box to turn on **Share this printer**.

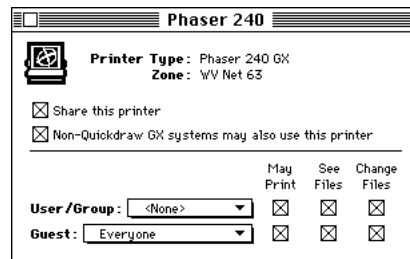

5. Click the close box.
6. At the alert message, click **Save**.
7. The desktop printer's icon changes to reflect the change in status to a shared printer.



Using a shared printer

If you want to use a printer hosted by another user's computer, do the following:

1. Open the **Chooser** from the **Apple** menu.
2. Click the **Phaser 240 GX** printer driver icon on the left side of the **Chooser**.
3. In the **Connect via** field's pop-up menu, select **Servers**.
4. The list of printers in the **Chooser** changes to show only shared printers. Click on the shared printer you want to use.
5. Close the **Chooser**.

Printing from QuickDraw GX-aware applications

If you are using QuickDraw GX applications with the Phaser 240 GX driver, the **Page Setup** and **Print** dialog boxes look different from the standard LaserWriter 7.1.2 dialog boxes described in Chapter 2.

Using the Page Setup command

When you select **Page Setup** from the **File** menu, the following dialog box appears:

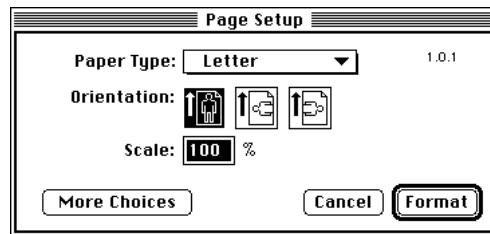

When you click the **More Choices** button, the dialog box expands to show the following options:

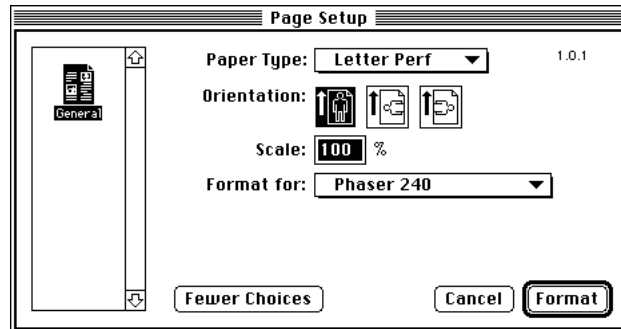

Page Setup options

- **Row of icons:** The scrollable icon list on the left side of the dialog box represents printing extensions that are available to the printer driver. When selected, the **General** icon displays the normal **Page Setup** options. Select another icon to see a new set of options.

Refer to Apple's QuickDraw GX documentation for instructions on installing printing extensions; refer to page A-9 to use the **Extensions Setup** command in the **Printing** menu to enable installed printing extensions.

- **Paper Type:** This is a list of page sizes available for the selected printer. Refer to page 5-2 for page size details.
- **Orientation:** This is a standard driver option. Refer to page 5-10 for image orientation details.
- **Scale:** This is a standard driver option.
- **Format for:** This pop-up menu allows you to select a different desktop printer for formatting your document.

Using the Print command

When you select **Print** from the **File** menu, the following dialog box appears:

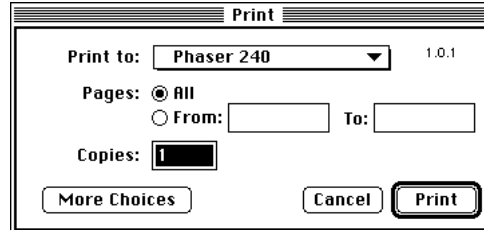

When you click the **More Choices** button, the dialog box expands to show the following options:

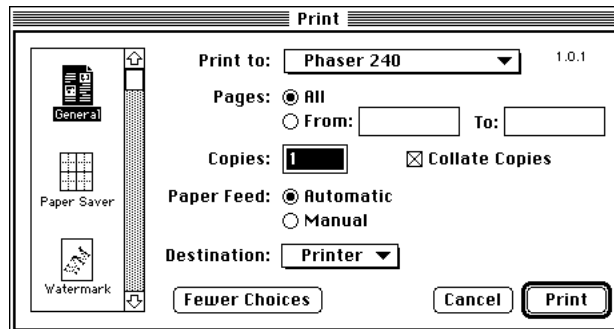

Print dialog box options

- **Row of icons:** The scrollable icon list on the left side of the dialog box lists printing extensions that are available to the printer driver. When selected, the **General** icon displays the normal **Print** options. Select another icon to see a new set of options. **Print Time** and **Paper Match** are part of the QuickDraw GX software and are always available.
- The rest of the options in this dialog box are standard driver options described in Apple documentation.

Using the TekColor printing extension

Select the **TekColor** icon at left of the dialog box to see printer options:

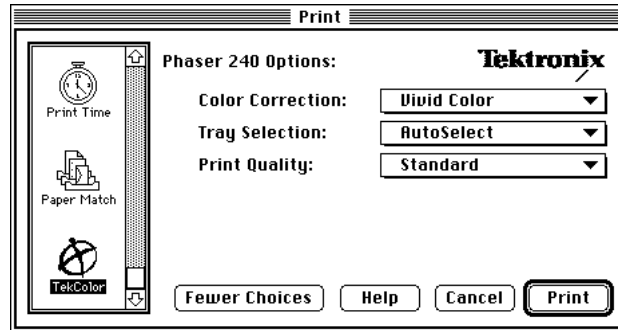

Note This dialog box is similar to the one that appears when you select **Printer Driver Defaults** from the **Printing** menu; refer to page A-10 for details.

The default settings in this dialog box reflect the defaults for the selected desktop printer. With most applications, you can change the printing options and save those options with each document.

Using the Paper Match printing extension

This dialog box lets you specify paper trays. A paper tray selection in the **Paper Match** printing extension overrides the tray selection choice in the TekColor printing extension. You should use the **TekColor** printing extension for selecting *all* printing options.

Printing from non-QuickDraw GX-aware applications

If you are using non-QuickDraw GX applications with the Phaser 240 GX driver, the **Page Setup** and **Print** dialog boxes look similar to the standard LaserWriter 7.1.2 dialog boxes described in Chapter 2. However, unlike the dialog boxes described in Chapter 2, these dialog boxes have no printer-specific options, such as TekColor color corrections. These dialog boxes reflect the selections made in the default desktop printer. You cannot change these printer settings from an application, but you can change them by selecting (highlighting) the default desktop printer and using the **Printer Driver Defaults** command in the **Printing** menu. You can also change the default desktop printer before you change printing selections; see page A-8 for instructions.

Changing a desktop printer's default selections

1. Click to highlight the default desktop printer.



2. From the **Printing** menu, select **Printer Driver Defaults**. The following dialog box appears:

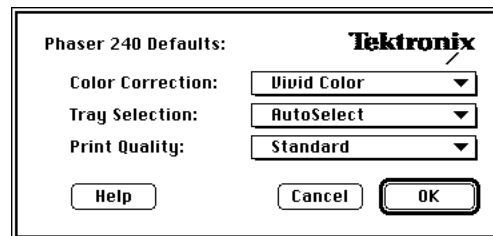

3. Make desired printer selections, then click **OK**.
4. Return to your application.

Disabling QuickDraw GX

You may want to disable QuickDraw GX when printing from some non-QuickDraw GX applications so you can use the Phaser 240 printer driver (based on the LaserWriter 7.1.2 driver) described in Chapter 2.

1. Open the **Extensions** folder inside the **System Folder**.
2. Drag the **QuickDraw GX** extension onto the desktop.
3. Select **Restart** from the **Special** menu.

Any desktop printers created before you disabled QuickDraw GX will have an “X” drawn through the icons. These desktop printers remain unavailable for use until QuickDraw GX is re-enabled.

Viewing printer status

Once you send a print to a desktop printer, you can monitor the status of the print job in the Printer Status dialog box. There are two ways to open the **Printer Status** dialog box:

- Select (highlight) the appropriate desktop printer icon, then select **Open** from the **File** menu.
- Double-click the appropriate desktop printer icon.

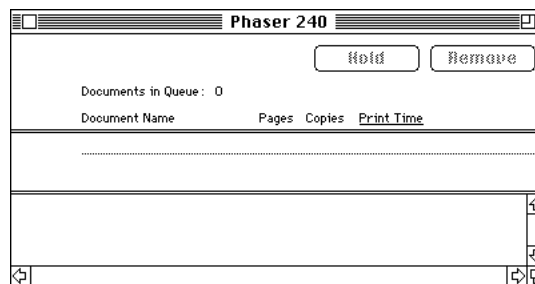

B

Modifying Printer Operations

This appendix explains how to modify printer operation by:

- Enabling and disabling the startup page
- Printing a configuration page
- Changing the EtherTalk zone

Enabling and disabling the startup page

Note *If you are using a Macintosh with QuickDraw GX and System Software 7.5, you can use the Tektronix Phaser 240 GX driver to print a copy of the startup page without turning the printer off and on. Refer to page A-11 for instructions.*

You can choose to have a startup page print each time the printer is turned on or reset, or you can disable the startup page.

Use the files for your computer type.

Macintosh file name	PC file name
<i>LaserWriter Utility</i>	<i>NOSTRTPG.PS</i> <i>STARTPG.PS</i>

Macintosh users

1. Follow the instructions on page 2-13 to decompress the *Phaser 240 Utilities.sea* archive file on the Macintosh Driver and Printer Utilities diskette to your computer's hard disk.
2. Select the appropriate printer in the **Chooser**.
3. Locate the *LaserWriter Utility* in the folder on your hard disk containing decompressed utility files.
4. Double-click the *LaserWriter Utility* icon to start the application.
5. Choose **Set Startup Page** from the **Utilities** menu.
6. Select either the **on** or **off** button, then click **OK**.

PC and workstation users

- Use the *STARTPG.PS* file to enable printing of the printer's startup page.
 - Use the *NOSTRTG.PS* file to stop the printer from printing a startup page.
1. Locate the start page files in the *PHSR240* directory on the Windows 3.1 Driver and Printer Utilities diskette.
 2. Copy the files to your hard disk, or use the files from the diskette.
 3. Use one of the following methods to send the desired file to the printer:
 - **PC users:** Use the DOS **COPY** command, described on page 3-19, to send a file to the printer.
Or, use the **Copy** command in Windows **File Manager**, described on page 3-20, to send a file to the printer.
 - **Workstation users:** Send a file to the printer as you would any PostScript file.

Printing a startup page

Follow these steps to print a copy of the printer's startup page:

1. Enable the startup page if it is not already enabled.
2. Turn the printer's power switch off then back on.
Or, reset the printer according to instructions on page 8-23.

Printing a configuration page

Note If you are using a Macintosh with QuickDraw GX and System Software 7.5, you can use the Tektronix Phaser 240 GX driver to print a copy of the configuration page. Refer to page A-11 for instructions.

A configuration page is similar to the printer's startup page, but it also provides details about each available port. Use the files for your computer type.

Macintosh file name	PC file name
<i>LaserWriter Utility and Configuration Page</i>	<i>PRNTCNFG.PS</i>

Macintosh users

1. Follow the instructions on page 2-13 to decompress the *Phaser 240 Utilities.sea* archive file on the Macintosh Driver and Printer Utilities diskette to your computer's hard disk.
2. Select the appropriate printer in the **Chooser**.
3. Locate the *LaserWriter Utility* in the folder on your hard disk containing decompressed utility files.
4. Double-click the *LaserWriter Utility* icon to start the application.
5. Choose **Download PostScript File** from the **Utilities** menu.
6. Select the *Configuration Page* file from the list, then click **Open**.
7. At the prompt `Save PostScript output as:` you are asked for a file name for saving printer output. Use either the default name given in the edit box or type a new name. Click **Save** to send the file to the printer.

8. If no output is returned by the printer, the *LaserWriter Utility* displays a dialog box. Click **OK** in the box to continue.

PC and workstation users

1. Locate the *PRNTCNFG.PS* file in the *PHSR240* directory on the Windows 3.1 Driver and Printer Utilities diskette.
2. Copy the file to your hard disk, or use the file from the diskette.
3. Use one of the following methods to send the file to the printer:
 - **PC users:** Use the DOS **COPY** command, described on page 3-19, to send the *PRNTCNFG.PS* file to the printer.
Or, use the **Copy** command in Windows **File Manager**, described on page 3-20, to send the *PRNTCNFG.PS* file to the printer.
 - **Workstation users:** Send the *PRNTCNFG.PS* file to the printer as you would any PostScript file.

Setting the printer's EtherTalk zone

A *zone* is a logical grouping of networked devices, such as an engineering or marketing zone. Ask your network administrator which zone your printer should be in.

Since a network needs to be able to uniquely identify any device, you must make sure the zone on EtherTalk is different from the zone on LocalTalk. If you make the EtherTalk zone the same as the LocalTalk zone, the printer automatically makes the name seen on the LocalTalk network different from the name seen on the EtherTalk network. For example, the default printer name **Phaser 240** would be changed to **Phaser 240 (via LocalTalk)**. This automatic renaming keeps the printer operational regardless of zone or name conflicts and lets you distinguish the high-speed Ethernet connection from the slower LocalTalk connection.

Use the files for your computer type.

Macintosh file name	PC file name
<i>LaserWriter Utility and Set EtherTalk Zone</i>	<i>ETHRZONE.PS</i>

Macintosh users

With devices grouped into zones, you can use the **Chooser** to see all the printers in any zone.

To designate the EtherTalk zone, use the *Set EtherTalk Zone* utility file. You will have to edit this file. You must have a copy of TeachText, or SimpleText for System Software 7.1 and higher, installed on your hard disk to do this editing. If you don't have a copy already installed, copy TeachText or SimpleText from the same Apple system software diskettes you last used to upgrade your computer.

If you have both LocalTalk and Ethernet cables as part of the same Apple Internet, it is recommended that you connect only the Ethernet cable. There is no benefit to making both LocalTalk and Ethernet connections to the printer if both cables are part of the same Apple Internet. See the *Phaser 240 Color Printer User Manual* for information on printer behavior in this configuration.

To designate the zone on EtherTalk, use the *Set EtherTalk Zone* file. You must edit this file.

1. Follow the instructions on page 2-13 to decompress the *Phaser 240 Utilities.sea* archive file on the Macintosh Driver and Printer Utilities diskette to your computer's hard disk.
2. View the *Set EtherTalk Zone* file in TeachText or SimpleText.
3. Replace the name within the parentheses (*My Zone Name*) with the name of the EtherTalk zone your printer is in.
4. Save the file and quit the application.
5. Select the appropriate printer in the **Chooser**.
6. Locate the *LaserWriter Utility* in the folder on your hard disk containing decompressed utility files.
7. Double-click the *LaserWriter Utility* icon to start the application.
8. Choose **Download PostScript File** from the **Utilities** menu.
9. Select the *Set EtherTalk Zone* file from the list, then click **Open**.
10. At the prompt `Save PostScript output as:` you are asked for a file name for saving printer output. Use either the default name given in the edit box or type a new name. Click **Save** to send the file to the printer.
11. If no output is returned by the printer, the *LaserWriter Utility* displays a dialog box. Click **OK** in the box to continue.

PC and workstation users

To designate the zone on EtherTalk, use the *ETHRZONE.PS* file. You must edit this file.

1. Ask your network administrator which zone you should use.
2. Locate the *ETHRZONE.PS* file in the *PHSR240* directory on the Windows 3.1 Driver and Printer Utilities diskette.
3. Copy the file to your hard disk.
4. View the *ETHRZONE.PS* file in a text editor, and replace the name within the parentheses (*My Zone Name*) with the name of the EtherTalk zone that your printer is in.
5. Save the file and quit.
6. Use one of the following methods to send the file to the printer:
 - **PC users:** Use the DOS **COPY** command, described on page 3-19, to send the *ETHRZONE.PS* file to the printer.
Or, use the **Copy** command in Windows **File Manager**, described on page 3-20, to send the *ETHRZONE.PS* file to the printer.
 - **Workstation users:** Send the *ETHRZONE.PS* file to the printer as you would any PostScript file.

C

Using Different Printer Language Modes

This appendix is for PC or workstation users who want to use PostScript, HP-GL (Hewlett-Packard Graphics Language), or monochrome PCL5 (Printer Command Language) printer languages. It explains how to perform the following tasks:

- Setting PostScript and HP-GL timeouts
- Changing the printer's language mode
- Testing the printer's language mode
- Setting default HP-GL pen colors

Setting PostScript and HP-GL job and wait timeouts

Note The HP-GL job timeout is the same as the PostScript job timeout.

The *CONFIG.PS* file changes the PostScript and HP-GL job and wait timeout values. Changes are persistent across print jobs but not across printer power cycles.

- The **wait timeout** is the amount of time in seconds that the printer waits for data to come from the computer during a job. If the data stream pauses for longer than the specified number of seconds, a timeout error is generated, and the job is canceled.
- The **job timeout** is the amount of time any single job may be active before it must print.
 - In PostScript mode, if the value is exceeded, a *timeout* error is generated.
 - In HP-GL mode, if the timeout value is too small, an image may be split across two pages; if the value is too large, multiple-page prints may be combined on one page.

Note The *CONFIG.PS* file affects printer operation. If the printer is shared on a network, using this file may affect the prints requested from other users.

To change the timeout values, follow these steps:

1. If necessary, configure the printer port to receive PostScript; see page C-5 for instructions.
2. Locate the *CONFIG.PS* file in the *PHSR240* directory on the Windows 3.1 Driver and Printer Utilities diskette.
3. Open the *CONFIG.PS* file in a text editor.
4. The default values for the printer are **0** seconds for the job timeout and **40** seconds for the wait timeout. A timeout value of **0** indicates no timeout; the printer waits indefinitely.

To change *CONFIG.PS* to specify different timeouts, substitute new values for **0** and **40** in the **JobTimeOut** and **WaitTimeOut** lines. Permitted timeout values are as follows:

- **JobTimeOut:** 0 to 999
- **WaitTimeOut:** 0, or 15 to 999
- **ManualFeedTimeout:** 0 to 999
- To specify no timeout, use **0**

Note *To avoid timeouts or job cancellation on Windows multiple-page or multiple-copy print jobs, you may want to set the **WaitTimeOut** to a high value or to 0 (zero).*

In the following example, the timeouts are set to their default values.

```
3 dict begin
  /Password() def
  /JobTimeOut 0 def
  /WaitTimeOut 40 def
currentdict end setsystemparams
1 dict begin
  currentpagedevice /ManualFeedTimeout known
{ /ManualFeedTimeout 60 def } if
currentdict end setpagedevice
```

5. Use one of the following methods to send the file to the printer:
 - **PC users:** Use the DOS **COPY** command, described on page 3-19, to send the *CONFIG.PS* file to the printer. Or, use the **Copy** command in Windows **File Manager**, described on page 3-20, to send the *CONFIG.PS* file to the printer.
 - **Workstation users:** Send the *CONFIG.PS* file to the printer as you would any PostScript file.

Changing the printer's language mode

The Phaser 240 supports the following printer languages:

- PostScript Level 1 and Level 2
- HP-GL (Hewlett-Packard Graphics Language)
- Monochrome PCL5 (Printer Command Language)

In the factory default configuration, the printer expects to receive PostScript data on all ports. If you want to use an HP-GL application, you must explicitly set up a printer port for HP-GL data, or enable Adobe IntelliSelect™ automatic language selection. If you want to use a PCL5 application, you must enable automatic language selection on a port.

Changing the language of the printer between PostScript, HP-GL, and PCL5 is port-specific. The ports, such as parallel or LocalTalk, can each be configured differently. You can change the default language on any port so whenever the printer is turned on it expects to receive PostScript, HP-GL, or PCL5 data on a specific port. If automatic language selection is enabled on a particular port, it becomes the default on that port, allowing you to change back and forth between PostScript, HP-GL, and PCL5 files.

Changes to the language on any port are persistent across print jobs and across printer power cycles.

Note *The following files affect printer operation. If the printer is shared on a network, using these files may affect the prints requested from other users.*

- To print PostScript files, use the *PSCRIPT.PS* file to set up a port to receive PostScript.
- To print HP-GL files, use the *HPGL.PS* file to set up a port to receive HP-GL.
- To print PCL5 files, use the *AIS.PS* file to set up a port for automatic language selection.

Printing PostScript files

The *PSCRIPT.PS* file changes a port to accept only PostScript data. After you copy this file to a port, the printer expects PostScript files on that port. The port's language change is persistent across print jobs and across printer power cycles.

Use one of the following methods to send the file to the printer:

- **PC users:** Use the DOS **COPY** command, described on page 3-19, to send the *PSCRIPT.PS* file to the printer.
Or, use the **Copy** command in Windows **File Manager**, described on page 3-20, to send the *PSCRIPT.PS* file to the printer.
- **Workstation users:** Send the *PSCRIPT.PS* file to the printer as you would any PostScript file.

Printing HP-GL files

The *HPGL.PS* file changes a port to accept only HP-GL data. After you copy this file to a port, the printer expects HP-GL files on that port. The port's language change is persistent across print jobs and across printer power cycles.

Use one of the following methods to send the file to the printer:

- **PC users:** Use the DOS **COPY** command, described on page 3-19, to send the *HPGL.PS* file to the printer.
Or, use the **Copy** command in Windows **File Manager**, described on page 3-20, to send the *HPGL.PS* file to the printer.
- **Workstation users:** Send the *HPGL.PS* file to the printer as you would any PostScript file.

Printing PCL5 files

The *AIS.PS* file changes a port to automatic language selection. After you copy this file to a port, the printer will accept monochrome PCL5, PostScript, or HP-GL files on that port. The port's language change is persistent across print jobs and across printer power cycles.

Use one of the following methods to send the file to the printer:

- **PC users:** Use the DOS **COPY** command, described on page 3-19, to send the *AIS.PS* file to the printer.
Or, use the **Copy** command in Windows **File Manager**, described on page 3-20, to send the *AIS.PS* file to the printer.
- **Workstation users:** Send the *AIS.PS* file to the printer as you would any PostScript file.

Testing the printer's language mode

HP-GL mode

HPGLTEST.PLT is an HP-GL file that prints a single line of text if the printer is operating in HP-GL mode.

Use one of the following methods to send the *HPGLTEST.PLT* file to the printer *after* you send *HPGL.PS*, to make sure the change was made correctly:

- **PC users:** Use the DOS **COPY** command, described on page 3-19, to send the *HPGLTEST.PLT* file to the printer.
Or, use the **Copy** command in Windows **File Manager**, described on page 3-20, to send the *HPGLTEST.PLT* file to the printer.
- **Workstation users:** Send the *HPGLTEST.PLT* file to the printer.

PostScript mode

PSTEST.PS is a PostScript file that prints a single line of text if the printer is operating in PostScript mode.

Use one of the following methods to send the *PSTEST.PS* file to the printer *after* you send *PSCRIPT.PS*, to make sure the change was made correctly:

- **PC users:** Use the DOS **COPY** command, described on page 3-19, to send the *PSTEST.PS* file to the printer.
Or, use the **Copy** command in Windows **File Manager**, described on page 3-20, to send the *PSTEST.PS* file to the printer.
- **Workstation users:** Send the *PSTEST.PS* file to the printer as you would any PostScript file.

Setting default HP-GL pen colors

Note *The HPGLPENS.PS file affects printer operation. If the printer is shared on a network, using this file may affect the prints requested from other users.*

The *HPGLPENS.PS* file changes the color and width of the default pen colors. The HP 7475A plotter actually has only six pens, but the printer's emulation supports up to 256 pens.

The pen color change is persistent across jobs but not across printer power cycles; it affects all HP-GL jobs that immediately follow it until the next printer reset.

Note *HP-GL pen settings cannot be made persistent across power cycles; pen settings revert to the default when the printer is turned off.*

In *HPGLPENS.PS*, pen number, pen width, red value, green value, and blue value are listed in parentheses after **/ColorSetup** as shown below.

```
/ColorSetup (pen_number width red_value green_value  
blue_value...)
```

In the example below, all pen widths are set to **0.35** millimeters. Pen 0 is white (this is the background pen color), pen 1 is black, pen 2 is red, pen 3 is green, pen 4 is blue, pen 5 is cyan, pen 6 is magenta, and pen 7 is yellow.

```
CTRL-D  
(%HP7475A%) << /Password (  
                    /ColorSetup (0 0.35 1.0 1.0 1.0  
                                   1 0.35 0.0 0.0 0.0  
                                   2 0.35 1.0 0.0 0.0  
                                   3 0.35 0.0 1.0 0.0  
                                   4 0.35 0.0 0.0 1.0  
                                   5 0.35 0.0 1.0 1.0  
                                   6 0.35 1.0 0.0 1.0  
                                   7 0.35 1.0 1.0 0.0)  
                    >> setdevparams  
CTRL-D
```

Allowable values for pen numbers are **0** through **255**. Pen width is measured in millimeters. Red, green, and blue values can be any number between **0.0** and **1.0**. The following table shows the red, green, and blue combinations for each of the eight basic colors.

HP-GL pen color values

Color	Red value	Green value	Blue value
red	1.0	0.0	0.0
green	0.0	1.0	0.0
blue	0.0	0.0	1.0
yellow	1.0	1.0	0.0
magenta	1.0	0.0	1.0
cyan	0.0	1.0	1.0
white	1.0	1.0	1.0
black	0.0	0.0	0.0

To add a new pen, you must redefine pens 0 through 7 first, then add the new pens that you want.

To set pen widths and colors to values other than those in *HPGLPENS.PS*, do the following steps:

1. If necessary, configure the printer port to receive PostScript; see page C-5 for instructions.
2. Open the *HPGLPENS.PS* file in a text editor.
3. Edit the file and substitute the values that you want for those in the file. Color values can be any decimal number between **0.0** and **1.0**.

For example, to change pen 4 to a purple color and a width of .5 mm, edit *HPGLPENS.PS* and change the line for pen number 4 to the following:

```
4 0.5 1.0 0.0 0.5
```

C *Using Different Printer Language Modes*

Use one of the following methods to send the file to the printer:

- **PC users:** Use the DOS **COPY** command, described on page 3-19, to send the *HPGLPENS.PS* file to the printer.
Or, use the **Copy** command in Windows **File Manager**, described on page 3-20, to send the *HPGLPENS.PS* file to the printer.
- **Workstation users:** Send the *HPGLPENS.PS* file to the printer as you would any PostScript file.

Index

A

- addctrld, UNIX shell script 4-5
- ADDCTRLD.BAT, PC utility file 3-24
- adjusting printed colors 6-1
- Adobe Illustrator, PANTONE Color library file
 - Macintosh 2-25
 - PC 3-29
- AIS.PS, PC utility file C-5
- Aldus FreeHand, PANTONE Color library file
 - Macintosh 2-26, 2-27
 - PC 3-30
- Aldus PageMaker, PANTONE Color library file
 - Macintosh 2-28
 - PC 3-31
- America On-Line, electronic mail address 8-6
- ANYTRAY.PS, PC utility file 5-6
- AppleTalk software, updating 8-8
- applications
 - color adjusting 6-9
 - extensions to driver 2-4
 - printing from
 - Macintosh 2-19
 - PC 3-25
 - QuickDraw GX A-1
 - unique drivers 2-4
- archive files, Macintosh 1-4
- auto selecting paper trays 5-6
- automated fax systems 8-2

B

- BBS (Bulletin Board Service) 8-1
- before you begin 1-1
- blue color adjust 6-10
- Bulletin Board Service (BBS) 8-1

C

- change printer's name 2-17, 3-22
- CIE colors 6-1
- CMYK Sampler, Macintosh utility file 6-14
- CMYK.PS, PC utility file 6-14
- color charts
 - CMYK 6-14
 - HSB 6-14
 - PANTONE 6-22
 - printing from a Macintosh 6-17, 6-23
 - printing from a PC 6-20, 6-25
 - printing from QuickDraw GX
 - printer driver A-12
 - RGB 6-14
- color corrections
 - from an application 6-9
 - Macintosh printer driver 2-6
 - Monochrome 6-12
 - no corrections 6-10
 - QuickDraw GX printer driver A-10, A-12
 - Simulate Display 6-11
 - Simulate Press 6-11
 - use printer setting 6-7, 6-12, 8-21
 - using a Tektronix driver 6-7
 - using utility files 6-7
 - Vivid Color (blue) 6-10
 - Windows printer driver 3-11
- colors, adjusting or correcting 6-1
- commands, DOS
 - COPY command, using 3-19
 - MODE command, using 3-18
- communication ports 3-6
- compressed archive files, Macintosh 1-4
- CompuServe, electronic mail address 8-6
- CONFIG.PS, PC utility file C-2
- Configuration Page, Macintosh utility file B-4

- configuration page, printing
 - from a Macintosh B-4
 - from a PC B-4
 - from the QuickDraw GX printer driver A-12
- control startup page files
 - Macintosh B-2
 - PC B-2
 - QuickDraw GX printer driver A-12
- Control-D
 - PC utility files 3-24
 - workstation 4-4
- COPY command, using 3-19
- CorelDRAW!, PANTONE color library file
 - PC 3-32
- correcting printed colors 6-1
- CTRLD.PS, PC utility file 3-24
- customer support 8-1

D

- decompressing files
 - Macintosh screen fonts 7-4
 - Macintosh utility files 2-13
- delctrl, UNIX shell script 4-5
- desktop printers, QuickDraw GX
 - creating A-3
 - default desktop printer A-8
 - printing from A-6, A-20
 - renaming A-5
 - selecting unique features for A-5
 - shared desktop printers A-14, A-15
- diskettes
 - contents 1-4
 - locating 1-4
 - mounting instructions 4-6
- display colors, simulating 6-11
- DISPLAY.PS, PC utility file 6-6

- DOS
 - COPY command, using 3-19
 - MODE command, using 3-18
 - printing from 3-18
- downloading fonts
 - from a Macintosh 7-6
 - from a PC 7-8
- downloading printer utilities
 - from the QuickDraw GX printer driver A-11
- downloading utility files
 - from a Macintosh 2-12
 - from a PC 3-19
 - from the QuickDraw GX printer driver A-13
- drivers
 - installing
 - DOS 3-18
 - Macintosh LaserWriter 7.1.2-based 2-2
 - QuickDraw GX A-2
 - Windows 3-1, 3-14
 - using
 - DOS 3-18
 - Macintosh LaserWriter 7.1.2-based 2-4
 - QuickDraw GX A-5
 - Windows 3-9, 3-14

E

- electronic mail addresses 8-5, 8-6
- enhanced print quality 5-8
- Enhanced Quality, Macintosh utility file 5-8
- ENHANCED.PS, PC utility file 5-8
- error handlers, PostScript 8-9
- EtherTalk printer name 2-17, 3-22
- EtherTalk Zone, setting
 - Macintosh B-6
 - PC B-6
- ETHRZONE.PS, PC utility file B-6
- EuroHAL — Highly Automated Library for Europe 8-3
- eWorld, electronic mail address 8-6

F

- fax systems, information 8-2
- files, utility 1-2
- Font Sampler, Macintosh utility file 7-5
- font sampler, printing
 - from a Macintosh 7-5
 - from a PC 7-8
 - from the QuickDraw GX printer driver A-12
- fonts
 - decompressing, Macintosh 7-4
 - downloading from a Macintosh 7-6
 - downloading from Windows 7-8
 - installing, Macintosh 7-4
- FONTS.PS, PC utility file 7-8

G

- gray scale, printing in 6-12
- GX printer driver, *see QuickDraw GX printer driver*

H

- HAL — Highly Automated Library 8-2
- halftone screens, printer 8-18
- high-resolution print quality 5-8
- High Resolution, Macintosh utility file 5-8
- HIGHRES.PS, PC utility file 5-8
- HP-GL language C-4
- HP-GL pen colors C-8
- HPGL.PS, PC utility file C-5
- HPGLPENS.PS, PC utility file C-8
- HSB Sampler, Macintosh utility file 6-14
- HSB.PS, PC utility file 6-14

I

- image area 5-2
- image orientation 5-10
- information server 8-5
- interactions between drivers and utility files 1-2
- Internet 8-5
- introductory information 1-1

J

- job timeout C-2

L

- landscape orientation 5-10
- language modes
 - checking 8-15
 - HP-GL C-4
 - PCL5 C-4
 - PostScript C-4
 - testing C-7
- LaserWriter 8.x driver
 - installing 2-7
 - setup for a Phaser 240 2-7
 - using with a Phaser 240 2-10
- LaserWriter Utility
 - troubleshooting 8-22
- LaserWriter Utility, Macintosh utility file 2-14
- LocalTalk printer name 2-17, 3-22
- lower paper tray, selecting 5-6
- LOWRTRAY.PS, PC utility file 5-6

M

- Macintosh printer driver
 - installing 2-2
 - locating the software 1-2
 - Page Setup dialog box 2-5
 - paper sizes 5-4
 - Print dialog box 2-5
 - selecting printer in Chooser 2-3
 - system requirements 2-2
 - TekColor Options dialog box 2-6
 - using 2-4
- Macintosh READ ME files, reading 8-6
- Macintosh screen fonts, decompressing 7-4
- Macintosh utility files 2-14
 - CMYK Sampler 6-14
 - Configuration Page B-4
 - decompressing 2-13
 - Enhanced Quality 5-8
 - Font Sampler 7-5
 - High Resolution 5-8
 - HSB Sampler 6-14
 - LaserWriter Utility 2-14
 - locating the software 1-2
 - Monochrome 6-6
 - No Color Correction 6-6
 - PANTONE-Tek Phaser 240 6-23
 - printer description files 2-19
 - Raw CMYK 6-6
 - Raw RGB 6-6
 - Reset Printer 8-23
 - RGB Sampler 6-14
 - Set EtherTalk Zone B-6
 - Setscreen Patch 8-18
 - Simulate Display 6-6
 - Simulate Press 6-6
 - Standard Quality 5-8
 - Tek Error Handler 8-9
 - Use Any Tray 5-6
 - Use Lower Tray 5-6
 - Use Upper Tray 5-6
 - using 2-12
 - Vivid Color 6-6
- making the best color prints 1-1
- margins 5-2
- media
 - sizes, selecting 2-5, 3-9, 5-2, A-17
 - trays, selecting 5-6
 - type, selecting 5-12
- memory upgrades 8-11
- Microsoft Windows NT PostScript printer
 - driver, updating 3-14
- MODE command, using 3-18
- MONOCHRM.PS, PC utility file 6-6

- Monochrome color correction
 - description 6-12
 - Macintosh printer driver 2-6
 - QuickDraw GX printer driver A-10
 - selecting 6-7
 - Windows printer driver 3-11
- Monochrome, Macintosh utility file 6-6
- mounting PC diskette 4-6

N

- network printing 8-21
- NFS, *see* PC/NFS
- No color correction
 - description 6-10
 - Macintosh printer driver 2-6
 - QuickDraw GX printer driver A-10
 - selecting 6-7
 - Windows printer driver 3-11
- No Color Correction, Macintosh utility file 6-6
- NOCORECT.PS, PC utility file 6-6
- NT, Windows NT PostScript printer driver, updating 3-14

O

- orientation, image 5-10

P

- Page Setup dialog box
 - Macintosh printer driver 2-5
 - QuickDraw GX printer driver A-16
- page sizes 2-5, 3-9, 5-2, A-17
- PANT240.PS, PC utility file 6-23
- Pantone Colors, printing 8-17
- PANTONE printer files, using
 - Adobe Illustrator
 - Macintosh 2-25
 - PC 3-29
 - Aldus FreeHand
 - Macintosh 2-26, 2-27
 - PC 3-30
 - Aldus PageMaker
 - Macintosh 2-28
 - PC 3-31
 - color charts 6-22
 - CorelDRAW!
 - PC 3-32
- PANTONE-Tek Phaser 240, Macintosh utility file 6-23
- paper
 - sizes, selecting 2-5, 3-9, 5-2, A-17
 - trays, selecting 5-6
 - trays, troubleshooting problems 8-25
 - type, selecting 5-12
- Paper Match printing extension, QuickDraw GX printer driver A-19
- PC DOS, printing from 3-18

- PC utility files
 - ADDCTRLD.BAT 3-24
 - AIS.PS C-5
 - ANYTRAY.PS 5-6
 - CMYK.PS 6-14
 - CONFIG.PS C-2
 - CTRLD.PS 3-24
 - DISPLAY.PS 6-6
 - ENHANCED.PS 5-8
 - ETHRZONE.PS B-6
 - FONTS.PS 7-8
 - HIGHRES.PS 5-8
 - HPGL.PS C-5
 - HPGLPENS.PS C-8
 - HSB.PS 6-14
 - locating the software 1-2
 - LOWRTRAY.PS 5-6
 - MONOCHRM.PS 6-6
 - NOCORECT.PS 6-6
 - PANT240.PS 6-23
 - PRNTCNFG.PS B-4
 - PRNTNAME.PS 3-22
 - PSCRIPT.PS C-5
 - RAWCMYK.PS 6-6
 - RAWRGB.PS 6-6
 - RESET.PS 8-23
 - RGB.PS 6-14
 - SETNOSPG.PS B-2
 - SETSTPG.PS B-2
 - SIMPRESS.PS 6-6
 - STANDARD.PS 5-8
 - TEKEHAND.PS 8-9
 - UPPRTRAY.PS 5-6
 - using 3-19
 - VIVDCOLR.PS 6-6
- PC/NFS 3-8, 8-14
- PCL5 language C-4
- PDF files, using
 - Macintosh 2-24
 - Windows 3-28
- PDX files, using
 - Macintosh 2-21
 - Windows 3-26
- Pen colors, HP-GL C-8
- Phaser 240 (LaserWriter 7.1.2-based) printer
 - driver, *see Macintosh printer driver*
- Phaser Print software, workstations 4-2
- portrait orientation 5-10
- ports, *see communication ports*
- PostScript
 - error handlers 8-9
 - language C-4
 - Level 2 1-2
 - printing errors 8-7
 - random errors 8-8
 - timeout C-2
- PPD 3.0 files, using
 - Macintosh 2-21
 - PC 3-26
- PPD 4.x files, using
 - Macintosh 2-23
 - PC 3-27
- print a truer blue 6-10
- print area 5-2
- Print dialog box
 - Macintosh printer driver 2-5
 - QuickDraw GX printer driver A-18
- print quality modes
 - descriptions 5-8
 - Macintosh printer driver 2-6
 - QuickDraw GX printer driver A-10, A-12
 - selecting 5-8
 - Windows printer driver 3-11
- print speed, improving 8-11

- printer
 - halftone screens 8-18
 - language modes
 - HP-GL C-4
 - PCL5 C-4
 - PostScript C-4
 - memory upgrades 8-11
 - renaming 2-17, 3-22
 - resetting 8-23
 - startup page
 - enable or disable B-2
 - printing from the QuickDraw GX printer driver A-12
 - status reporting from the QuickDraw GX printer driver A-22
 - switches 6-8
 - using 1-2
- printer description files, using
 - Macintosh 2-19, 5-4
 - PC 3-25
- printer drivers
 - installing
 - DOS 3-18
 - Macintosh LaserWriter 7.2.1-based 2-2
 - QuickDraw GX A-2
 - Windows 3-1, 3-14
 - using
 - DOS 3-18
 - Macintosh LaserWriter 7.1.2-based 2-4
 - QuickDraw GX A-5
 - Windows 3-9, 3-14
- PRINTER.INF, updating Windows NT driver 3-14

- Printing menu, QuickDraw GX printer driver
 - Extension Setup command A-9
 - Input Trays command A-8
 - Printer Driver Defaults command A-10
 - Printer Utilities command A-11
 - Send PostScript File command A-13
 - Set Default Printer command A-8
 - Start Print Queue command A-7
 - Stop Print Queue command A-7
- printing on a network 8-21
- printing press, color correction 6-11
- printing problems 8-13
- PRNTCNFG.PS, PC utility file B-4
- PRNTNAME.PS, PC utility file 3-22
- PSCRIPT.PS, PC utility file C-5

Q

- quality modes, *see print quality modes*
- QuickDraw GX
 - disabling A-21
 - Tektronix printer driver A-1
- QuickDraw GX printer driver
 - color corrections A-10
 - desktop printers
 - creating A-3
 - renaming A-5
 - selecting a default A-8
 - sharing A-14
 - disabling QuickDraw GX A-21
 - downloading PostScript files A-13
 - downloading printer utilities A-11
 - installing A-2
 - locating the software 1-2
 - Page Setup dialog box A-16
 - Paper Match printing extension A-19
 - paper sizes 5-4
 - Print dialog box A-18
 - print quality modes A-10

- printer status A-22
 - printing extensions A-9
 - printing from
 - GX-aware applications A-6
 - non-GX aware applications A-6, A-20
 - Printing menu
 - Extension Setup command A-9
 - Input Trays command A-8
 - Printer Driver Defaults command A-10
 - Printer Utilities command A-11
 - Send PostScript File command A-13
 - Set Default Printer command A-8
 - Start Print Queue command A-7
 - Stop Print Queue command A-7
 - printing options A-10
 - selecting printer in Chooser A-3
 - startup page, printing A-12
 - system requirements A-1
 - TekColor printing extension A-19
 - tray selections A-10
 - using a shared desktop printer A-15
 - when to use A-1
- R**
- Raw CMYK, Macintosh utility file 6-6
 - Raw RGB, Macintosh utility file 6-6
 - RAWCMYK.PS, PC utility file 6-6
 - RAWRGB.PS, PC utility file 6-6
 - READ ME files, Macintosh, reading 8-6
 - rename printer 2-17, 3-22
 - RESET.PS, PC utility file 8-23
 - resetting the printer
 - from a Macintosh 8-23
 - from a PC 8-24
 - from the QuickDraw GX
 - printer driver A-12
 - RGB Sampler, Macintosh utility file 6-14
 - RGB.PS, PC utility file 6-14
- S**
- screen fonts, Macintosh 7-4
 - .sea compressed archive files, Macintosh 1-4
 - Set EtherTalk Zone, Macintosh utility file B-6
 - SETNOSPG.PS, PC utility file B-2
 - Setscreen Patch, Macintosh utility file 8-18
 - Setscreen Patch, using
 - from a Macintosh 8-18
 - from a PC 8-18
 - from the QuickDraw GX
 - printer driver A-12
 - SETSTPG.PS, PC utility file B-2
 - sharing desktop printers, QuickDraw GX printer
 - driver A-14
 - shell scripts, UNIX
 - addctrld 4-5
 - delctrld 4-5
 - simple color conversions, CMYK and RGB 6-13
 - SIMPRESS.PS, PC utility file 6-6
 - Simulate Display color correction
 - description 6-11
 - Macintosh printer driver 2-6
 - QuickDraw GX printer driver A-10
 - selecting 6-7
 - Windows printer driver 3-11
 - Simulate Display, Macintosh utility file 6-6
 - Simulate Press color correction
 - Macintosh printer driver 2-6
 - QuickDraw GX printer driver A-10
 - selecting 6-7
 - Windows printer driver 3-11
 - Simulate Press, Macintosh utility file 6-6
 - software diskettes 1-4
 - speed, print, improving 8-11
 - standard print quality 5-8
 - Standard Quality, Macintosh utility file 5-8
 - STANDARD.PS, PC utility file 5-8

- startup page, enable or disable
 - from a Macintosh B-2
 - from a PC B-2
 - from the QuickDraw GX
 - printer driver A-12
- startup page, printing, from the QuickDraw GX
 - printer driver A-12
- status reporting
 - from the QuickDraw GX
 - printer driver A-22
- support, customer 8-1

T

- technical support 8-1
- Tek Error Handler, Macintosh utility file 8-9
- Tek Error Handler, using
 - from a Macintosh 8-9
 - from a PC 8-9
 - from the QuickDraw GX printer driver A-12
- TekColor Dynamic Correction 6-1
- TekColor printing extension, QuickDraw GX
 - printer driver A-19
- TEKEHAND.PS, PC utility file 8-9
- Tektronix Bulletin Board Service 8-1
- Tektronix drivers 1-2
- Tektronix information server 8-5
- timeouts
 - job C-2
 - wait C-2
 - Windows printer driver 3-7
- Transmission Retry, Windows 3-7

- trays, paper, selecting 5-6
 - Macintosh printer driver 2-6
 - Macintosh utility files 5-6
 - PC utility files 5-6
 - QuickDraw GX printer driver A-10, A-12
- troubleshooting problems 8-25
 - Windows printer driver 3-9
- troubleshooting 8-2

U

- UNIX shell scripts
 - addctrld 4-5
 - delctrld 4-5
- upper paper tray, selecting 5-6
- UPPRTRAY.PS, PC utility file 5-6
- Use Any Tray, Macintosh utility file 5-6
- Use Lower Tray, Macintosh utility file 5-6
- Use Printer Setting color correction
 - description 6-12, 8-21
 - Macintosh printer driver 2-6
 - QuickDraw GX printer driver A-10
 - selecting 6-7
 - Windows printer driver 3-11
- Use Upper Tray, Macintosh utility file 5-6
- using color 6-4
- using the printer 1-2
- utilities
 - QuickDraw GX printer driver A-11
- utility files
 - locating the software 1-2
 - Macintosh
 - decompressing 2-13
 - using 2-12, 2-14
 - PC
 - using 3-19
 - setting color corrections 6-7
 - using the software 1-2

V

- VIVDCOLR.PS, PC utility file 6-6
- Vivid Color color correction
 - description 6-10
 - Macintosh printer driver 2-6
 - QuickDraw GX printer driver A-10
 - selecting 6-7
 - Windows printer driver 3-11
- Vivid Color, Macintosh utility file 6-6

W

- wait timeout C-2
- WIN.INI file, editing 7-7
- Windows NT printer driver
 - updating 3-14
 - using 3-14
- Windows printer driver
 - configuring 3-5
 - fonts 7-7
 - installing 3-3
 - installing on a network 3-12
 - locating the software 1-2
 - on-line help 3-2
 - Options dialog box 3-10
 - paper sizes 5-5
 - problems with setting page sizes 5-5, 8-20
 - Setup dialog box 3-9
 - system requirements 3-1
 - timeouts 3-7, 8-16
 - using 3-9
 - using fonts 7-7
- workstations
 - Control-D characters 4-4
 - diskette mounting instructions 4-6
 - Phaser Print software 4-2
 - printing from 4-1
 - shell scripts 4-5
- Worldwide Web, electronic mail address 8-6

Z

- zones, Ethertalk B-6